

stepping motor controls



power amplifier boards

position controls

equipment

www.stoegra.de

stögra
ANTRIEBSTECHNIK GMBH



driving

motion control

positioning

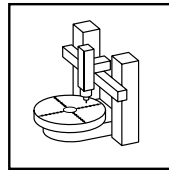
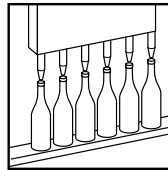
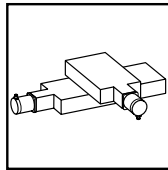
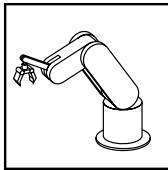
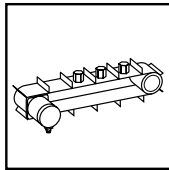
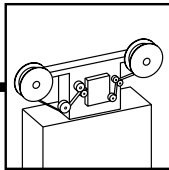

STÖGRA Antriebstechnik GmbH

Machtlfinger Straße 24
D-81379 München

Tel: +49 89 15 90 40 00

Fax: +49 89 15 90 40 09

E-Mail: info@stoegra.de

Internet: <http://www.stoegra.de>

All rights reserved

Without written approval we don't allow any reprint and partial copying.

We reserve the right to make engineering changes, refinements and improvements to all products described herein.

Mechanical and electrical ratings and dimensions are, therefore, subject to change without notice.

No liability whatsoever is accepted.

Edition: December 2011

general product overview	4
stepping motor controls	
general explanations	5
stepping motor power amplifier boards in eurocard format series SE	
standard series SE...V3 and SE...E50 V3	6
microstepping series SE P05...V2	9
stepper motor power amplifier in compact housing series WSE	
mains ready 230VAC and 115VAC – series WSE ...230AC V01	10
20 to 80VDC and 4A per phases – series WSE 04.80 V01	14
20 to 80VDC and 8A per phases – series WSE 08.80 V01	14
power supplies series NT	16
board holder KH-SE_01	17
front panels for power amplifier boards series SEE	17
panel mount / 19 inch-systems series ELK / ELR	18
position controls series SERS	
modes of operation	24
overview functions	26
programming via RS232 and RS485	28
SERS Programmer 2	29
SERS with Closed Loop control	30
encoder input	31
SERS with Profibus-DP	32
SERS with PROFIdrive	33
SERS with CANopen	33
seperate 24V logic supply	34
SERS block diagram	35
specifications, versions, ordering key	36
position controls in compact housing series WSERS	
mains ready 230VAC and 115VAC – series WSERS...230 AC V01	37
20 to 80VDC and 4A per phases – series WSE 04.80 V01	37
20 to 80VDC and 8A per phases – series WSE 08.80 V01	37
connections	38
dimensions, ordering key, specifications, equipment	39
equipment SERS / WSERS	39

4 General product overview

STÖGRA Stepping motor controls are designed in a modular system, as **STÖGRA Stepping motors** (see catalogue STEPPING MOTORS)

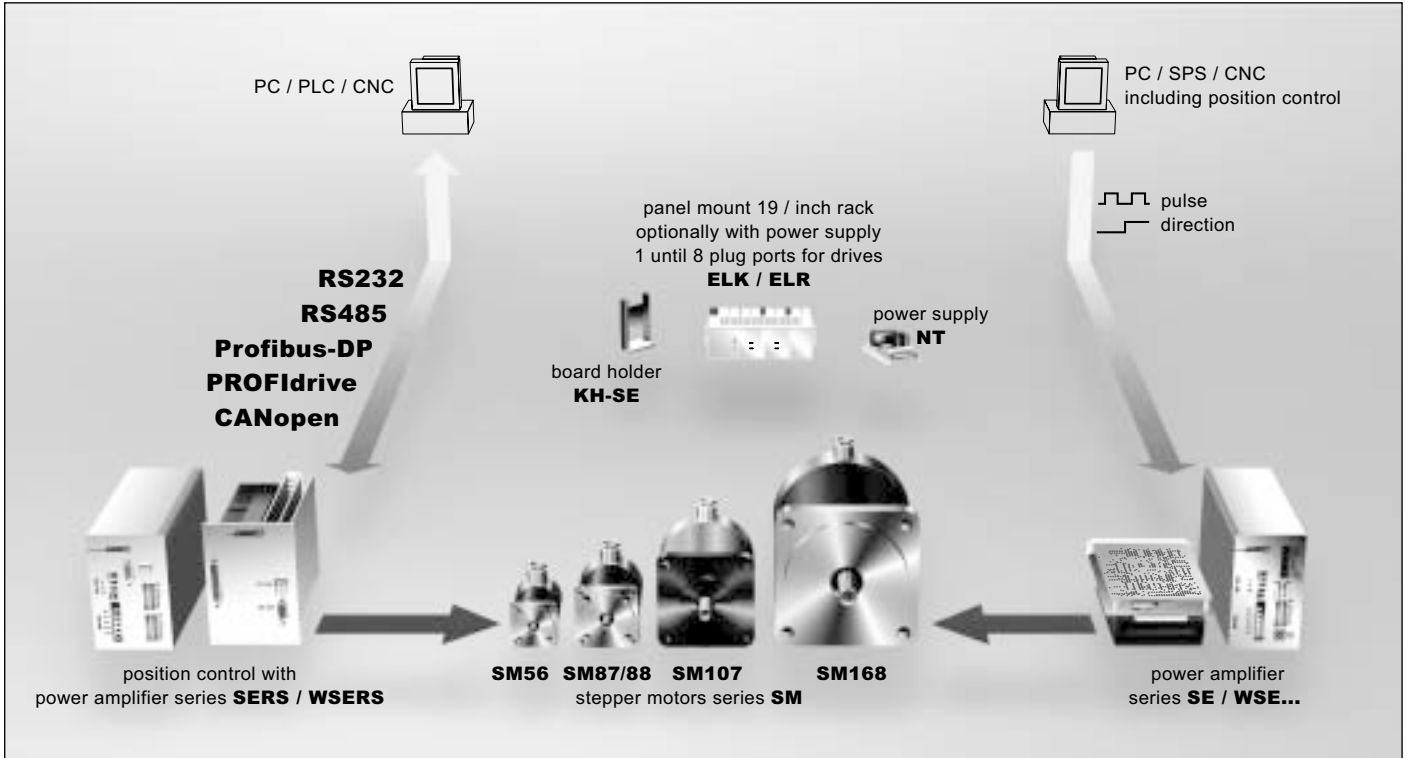

Overview Controls

Power amplifier boards in eurocard format Series SE... V31/33 optionally with control of load angle Voltage supply Phase current Step resolution 24 – 240 VDC 0 – 14,5 A/phase 200 – 1000 steps/rev. catalogue pages 6 to 8, housings for SE boards at page 18 to 23		
Microstepping power amplifier boards Series SE P05...V2 Voltage supply Phase current Step resolution 24 – 240 VDC 0 – 14,5 A/phase 200 – 12800 steps/rev. catalogue page 9, housings for SE boards at page 18 to 23		
Power amplifiers in compact housing Series WSE ...230AC V01 and WSE ...80 V01 optionally with control of load angle Voltage supply Phase current Step resolution 20 – 80 VDC 0 – 4 and 8 A/ph. 200 – 12800 steps/rev. 115 VAC and 230 VAC 0 – 4 and 6 A/ph. catalogue pages 10 to 15		
Position controls including power amplifier Series SERS with interface RS232, RS485, Profibus-DP, PROFIdrive, CANopen Voltage supply Phase current Step resolution 24 – 240 VDC 0 – 14,5 A/phase 12800 steps/rev. catalogue pages 24 to 32, housings for SERS boards at page 18 to 23		
Position controls including power amplifier in compact housings Series WSERS...230AC V01 and WSERS ...80 V01 with interface RS232, RS485, Profibus-DP, PROFIdrive, CANopen Voltage supply Phase current Step resolution 20 – 80 VDC 0 – 4 and 8 A/ph. 12800 steps/rev. 115 VAC and 230 VAC 0 – 4 and 6 A/ph. catalogue pages 33 to 35		

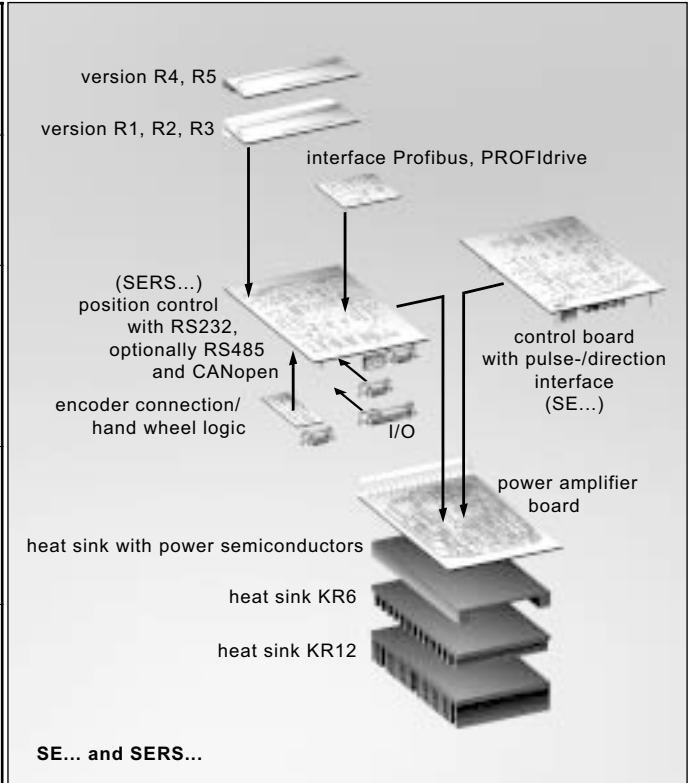

STÖGRA Stepping motor controls are designed as modular system. The power stage with the power-semiconductors is used for the power amplifier boards as well as for the position controls. The different field bus interfaces for the position controls are realized by internal plug boards. This enables a great type variety for the most different requirements and many different control systems. Also it gives the possibility to keep most parts (basic components) on stock and enables cost effective production due to the low quantity of different basic types.

For housings for power amplifier boards and position controls in eurocard format please see our series ELK/ELR (page 18 to 21).

General function principle – Step resolution and max. load angle (accuracy of positioning)

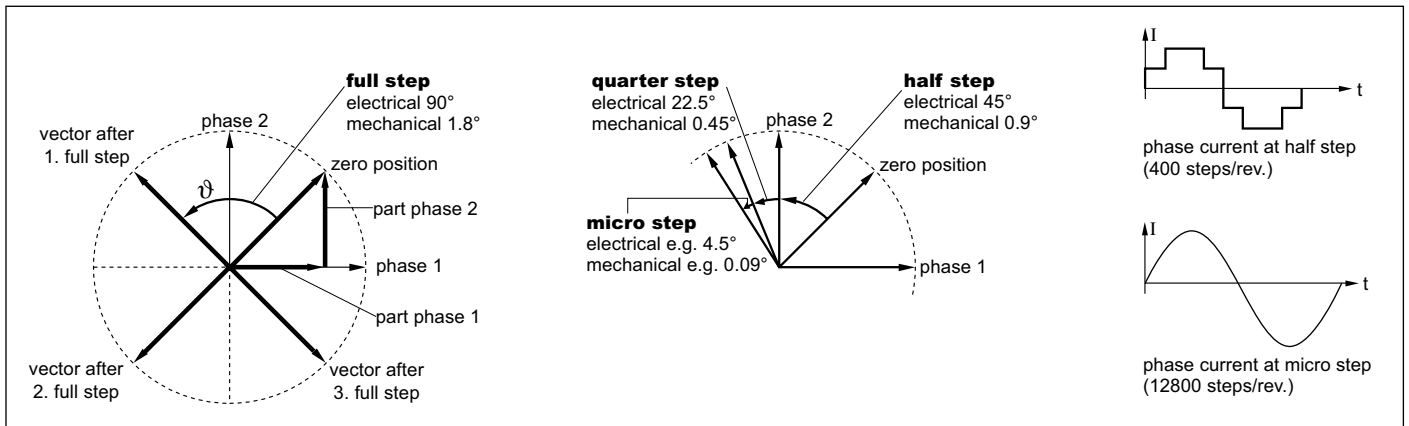

Switching onwards the stator field – shown in a field-vector-diagram

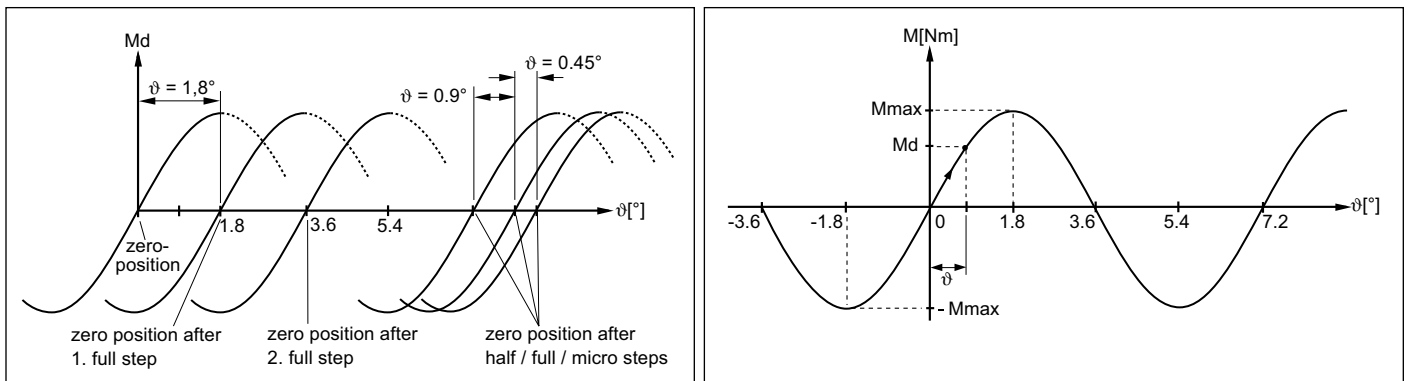

Switching onwards the stator field shown in a load angle-operating torque-diagram

Load angle: Excursion ϑ of the rotor in reference to the zero position determined by the stator field, in case of a torque M_d at the motor shaft

A stepping motor having 50 teeth on the rotor surface (motor with 50 poles) produces every 7.2° (mechanically) a stabile position (zero position) at motor stand still – regardless the number of phases (2, 3 or 5 phases)! The zero position is determined by the stator field.

The stator field is moved from the power amplifier »step by step« and the rotor follows the stator field. In case of big steps (full step – 200 steps/rev., half step – 400 steps/rev.) and low speed the motor is running rough with strong vibrations. Smaller steps result in smoother running. At high step resolutions (e.g. 12800 steps/rev.) there will be a very smooth true running without vibrations.

At motor stand still, in case of a load (torque M_d), the motor shaft will be moved the angle ϑ out of its zero position. The maximum possible movement away from the zero position is -1.8° at $-M_{max}$ and $+1.8^\circ$ at M_{max} **independent of the step resolution and 2, 3 or 5 phases (!!!)** (in case of a rotor with 50 teeth).

In most applications there can be achieved between 0.1° and 0.9° accuracy of positioning (in case of sufficient high step resolution of the control), depending on the mechanics (friction, etc.) and the sizing of the motor in the application.



General specifications of STÖGRA Stepping motor amplifier boards:

- All boards can be configured easily via DIP-switches (e.g. selection of step angle, signals Low/High-Active or activating of phase current reduction at stand still)
- The integrated control of step angle in series SE ... E50 V.. together with a stepping motor with mounted encoder E50 enables to monitor a mechanical overload (synchronous running interrupted) at the stepping motor. Therefore the load angle of the stepping motor is controlled continuously (control pulses and encoder pulses are being compared).
- LEDs enable quick and easy diagnostics of error and status. During operation the status of the phases is displayed by four red LEDs. An electrical error – short circuit (motor phases), over temperature (amplifier) or undervoltage – is displayed by a yellow LED. At series SE ...E50 V3 a mechanical error (exceeding of the max. load angle e.g. in case of mechanical overload at the stepping motor) is displayed by an additional yellow LED.
- Error signals respective a ready signal can be used externally via a potential free output.
- STÖGRA** power amplifier boards are plug compatible to each other, also to former series SE 11 ...60 and SE ...120. Series SE ...E50 V3.. is compatible to the former series SE...E50 and SE...E50D. Series SE...V3.. is compatible to the former standard series SE... (e.g. SE 400.06.60), SE...B2, SE...V11/V13 and SE...V21/V23.

6 Stepping motor control amplifier board series SE...V3 and SE...E50 V3

Stepper motor power amplifier board series SE...V31 / SE...V33

- Bipolar 2-Phases-stepper motor power amplifier
- Compatible with STÖGRA / Zebotronics standard units SE ... (e.g. SE 400.06.85), SE... B... , SE...V11 / SE...V13 and SE...V21 / SE...V23
- Protected against short circuit, over temperature and under voltage
- Via DIP-switch selectable step resolutions: 200, 400, 500, 800 and 1000 steps per revolution
- Via DIP-switch selectable input signal levels High-active TTL or High-active PLC or Low-active
- For version SE... E50.. with encoder input for control of load angle (at connection of a stepper motor with encoder E50)

Dimensions

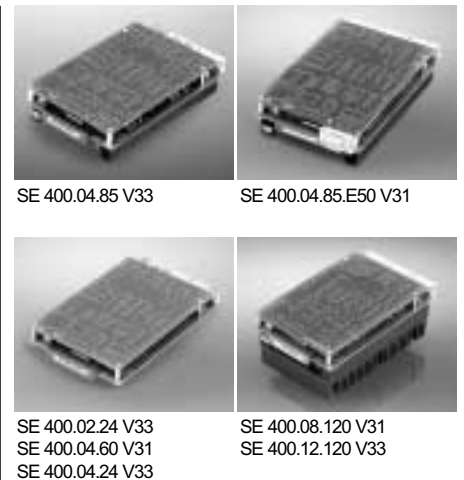
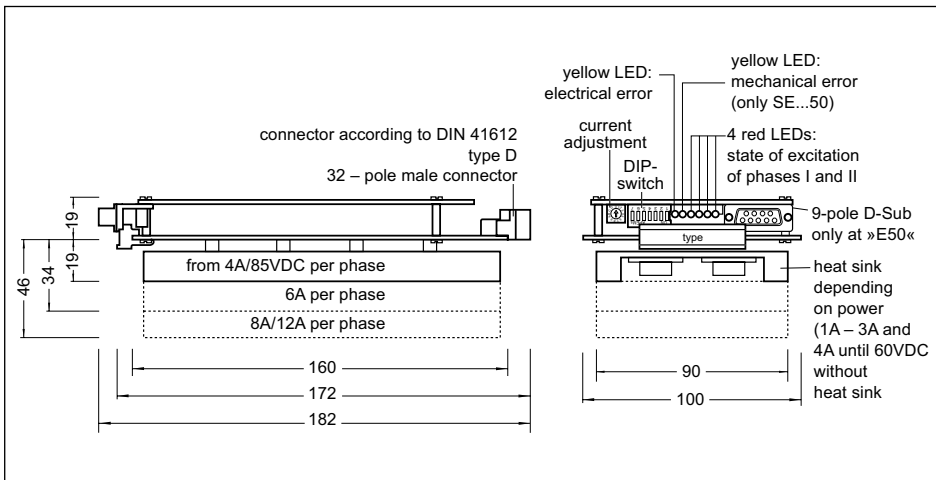

Dimensions series SE... V31/33

Adjustments via solder bridges

marker	notes	standard adjustment
M	open: enable output of a mechanical error closed: disable output of a mechanical error	E50 board open, else closed
F	internal function (do not change!)	closed
H	internal function (do not change!)	open

Selections of step resolution

X = switch in ON-position

W2	W1	W0	steps/rev.
			800
		X	400
	X		1000
	X	X	500
X			400
X		X	200
X	X		not valid
X	X	X	not valid

Automatical phase current reduction (switch »R«)

If switch »R« = OFF, then the phase current will be reduced by 50% at motor stand still. The first coming pulse at the pulse input will rise the phase current again to 100%. In case of an active reset signal the current reduction will not be activated.

M-function / double step (switch »M«)

If switch »M« = ON, then each signal edge at the pulse input will execute one motor step (the rising edge and the falling edge will execute one motor step each)

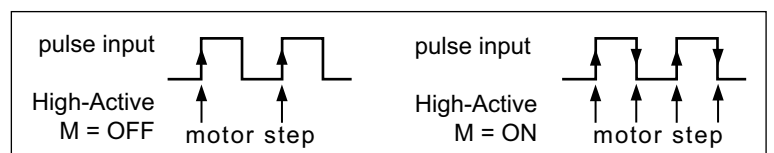

Stepping motor control amplifier board series SE...V3 and SE...E50 V3 7

Adjustment of phase current

Ex work the power amplifier board is set to its nominal current. The phase current must be adjusted depending on the connected stepper motor. The adjustment is done via the rotative switch at the boards front side according to below table. The values in the table correspond to the bipolar phase current of the motors.

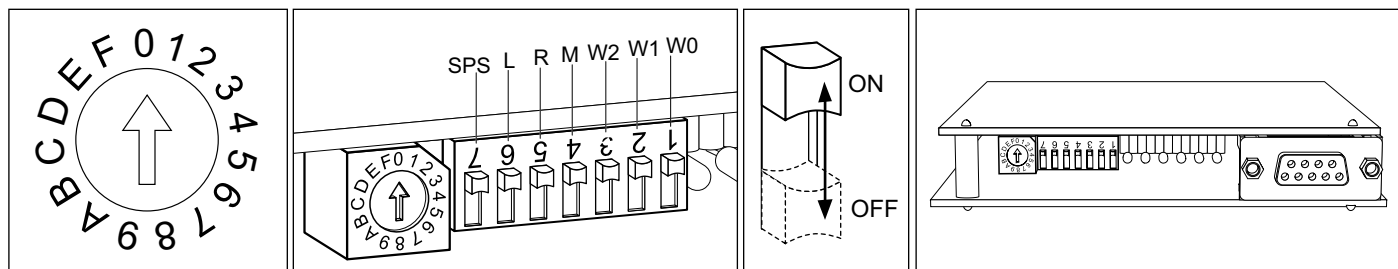

figure 3 to 4: phase current adjustment and selections via DIP-switch

phase current [A] nominal current / type	position of switch															
	0	1	2	3	4	5	6	7	8	9	A	B	C	D	E	F
1 A/Ph. SE ...01...	0,00	0,09	0,19	0,28	0,37	0,47	0,56	0,65	0,75	0,84	0,93	1,03	1,12	1,21	1,31	1,40
2 A/Ph. SE ...02...	0,00	0,18	0,38	0,56	0,74	0,94	1,12	1,30	1,49	1,68	1,86	2,06	2,24	2,42	2,62	2,80
3 A/Ph. SE ...03...	0,00	0,26	0,56	0,84	1,12	1,40	1,68	1,96	2,24	2,52	2,80	3,08	3,38	3,64	3,92	4,20
4 A/Ph. SE ...04..	0,00	0,36	0,76	1,12	1,48	1,88	2,24	2,60	2,98	3,36	3,72	4,12	4,48	4,84	5,24	5,60
6 A/Ph. SE ...06...	0,00	0,56	1,12	1,68	2,24	2,80	3,36	3,92	4,48	5,04	5,60	6,16	6,72	7,28	7,84	8,40
8 A/Ph. SE ...08...	0,00	0,48	1,68	2,52	3,36	4,20	5,04	5,88	6,72	7,56	8,40	9,24	10,1	10,9	11,8	12,6
12 A/Ph. SE ...12...	0,00	0,96	1,92	2,88	3,84	4,80	5,76	6,72	7,68	8,64	9,60	10,6	11,5	12,5	13,4	14,4

Input signals – selection of signal level

switch position	L = OFF and SPS = OFF	L = ON and SPS = OFF	L = OFF and SPS = ON	L = ON and SPS = ON
signal level	High-active TTL-level	Low-active	High-active SPS-level	not valid

Output – ready signal

SE... [E50] V31 and SE... [E50] V33:

ready signal: Indication of an electrical error or a mechanical error (at SE...E50 V...).
In non error state the relay contact is closed

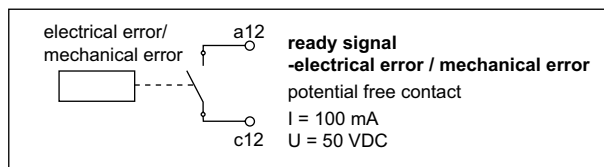

output – ready signal

Input signals

- Boost:** Rise of phase current by 20%
- Disable:** Disable motor phases – phase current is switched off
- Reset:** Drive errors are reset, drive in reset position (phase zero), pulse signals are disabled
- Direction:** Control of motor direction
- Pulse:** Each pulse executes one motor step
- Step Angle:** Switches step resolution from 1000 to 500 or 800 to 400 or 400 to 200 steps per revolution
The signal is always Low-Active and will work only at switch W0 in OFF-position.
- Ready signal:** (see fig. 5 and 6) indicates an **electrical error** (under voltage, short circuit or over temperature) respective **error mechanical** (only for SE...E50..). In non-error condition the relay contact is closed.

Input signals HIGH-active

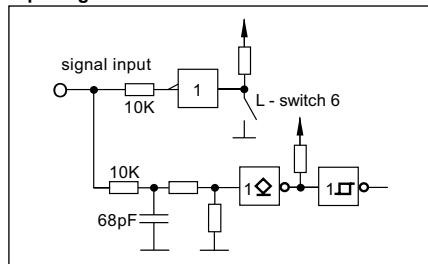

Input signals PLC – level

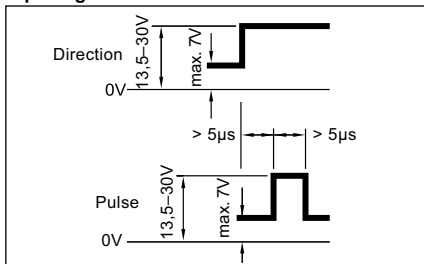

Input signals TTL – level

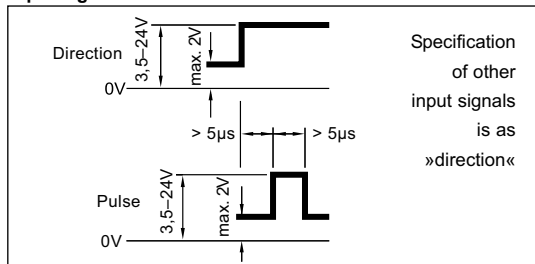

signal rise time max.: 1µs, signal fall time max.: 1µs, frequency pulse max.: 45 KHz

8 Stepping motor control amplifier board series SE...V3 and SE...E50 V3

Technical specifications

protection of the device	protection class IP00, protection against short circuit, over temperature and under voltage					
weight	nominal current [A/Ph]	1 – 3	4	6	8	12
	weight [Kg]	0,2	0,52	0,77	1,1	1,1
voltage supply	version	24	60	85	120	240
	range [VDC]	20 – 40	40 – 70	50 – 85	60 – 120	120 – 240
ambient conditions	ambient temperature: 0°C to 50°C, max. sink temperature: 85°C, forced draft: for amplifier boards with nominal current with 12A					
noise immunity	in case of correct installation: according to EN50082-2: – at selection TTL-signal level (switch SPS = OFF) the inputs are not immune against fast transients (burst)					
noise radiation	in case of correct installing and shielding or / and filtering of the lines and signals according to EN55011 class B					
RoHs conformdirective to 2002/95/EC						

Connections

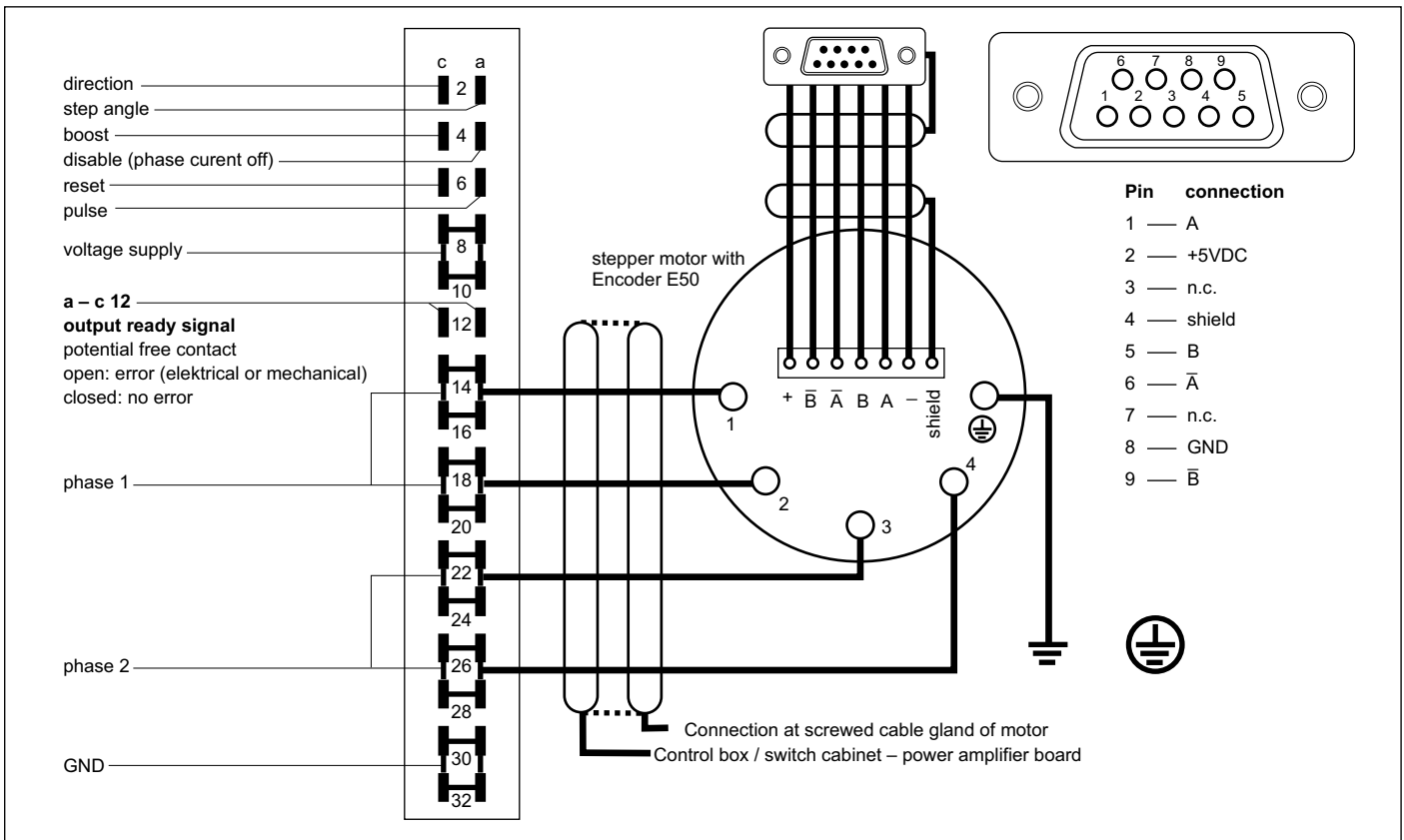

Ordering key: Example: SE 800.06.120 E50 V33 or SE 1000.04.85 V31

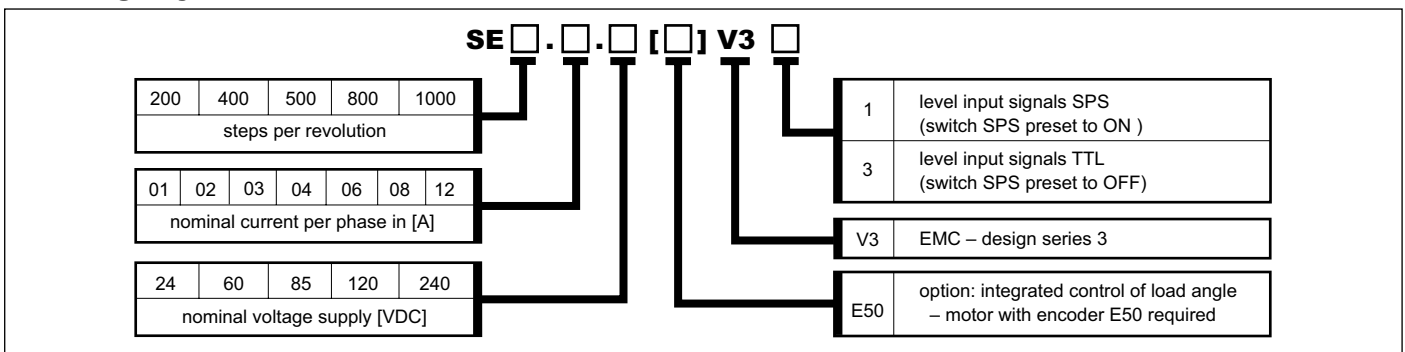

Restriction in possible combinations: 1A, 2A and 3A only with 24VDC and 60VDC, 240VDC only with 8A and 12 A

- Step resolution adjustable from 200 to 12800 steps / rev. and externally switchable
- Excellent truth micro stepping over the entire velocity range
- Electrically and mechanically compatible to standard amplifier (SE...V...)
- Shortcircuit, overtemperature and undervoltage protected
- Voltage range from 24VDC to 240VDC
- Phase current versions from 0 A / phase to 14,5 A / phase
- Constant torques for all pre-selected resolutions



SE P05...V2 Microstep

Step angle adjustment on the board

Different step angles can be selected via the switches C0, C1, C2 and C3. With the input »step angle« (Pin a2) the step angle can be switched externally between two values (switch »W« must be open!). During motion, switching the step angle is possible within the motor start-stop-frequency (when changing simultaneously the pulse frequency and step angle – at any frequency).

steps / revolution resolution switchable externally – PIN a2		Marker for step angle selection X = switch closed, else = switch open			
not active	active	C3	C2	C1	C0
2000	200	X	X	X	X
	400	X	X	X	
2500	500	X	X		X
3200	800	X	X		
4000	400	X		X	X
	800	X		X	
	1000	X			X
5000	500	X			
	1000		X	X	X
8000	800		X	X	
	2000		X		X
10000	400		X		
	1000			X	X
	2000			X	
12800	800				X
	1600				

There are further step angles available! Please ask at our sales office.

Adjustments via DIP-switches at the front side of the control board:

switch	denotes	
S0	phase current characteristics	further specifications: dimensions, input signals, output signals, phase current adjustment, voltage supply, general technical specifications as SE... V31/V33
C0 – C3	selection of step angle (see table above)	
W	activates row »Pin a2 active« of above step angle table »Pin a2 active« (external switching of step angle) is deactivated	
SPS	open: »TTL« – input level closed: »SPS – input level (PLC signal level)	
R	automatic current reduction (see SE...V3... page 6)	
L	open: signals High-Active – closed: signals Low-Active	

selectable adjustments

Available versions: (e.g.: SE P05.06.85 V2)

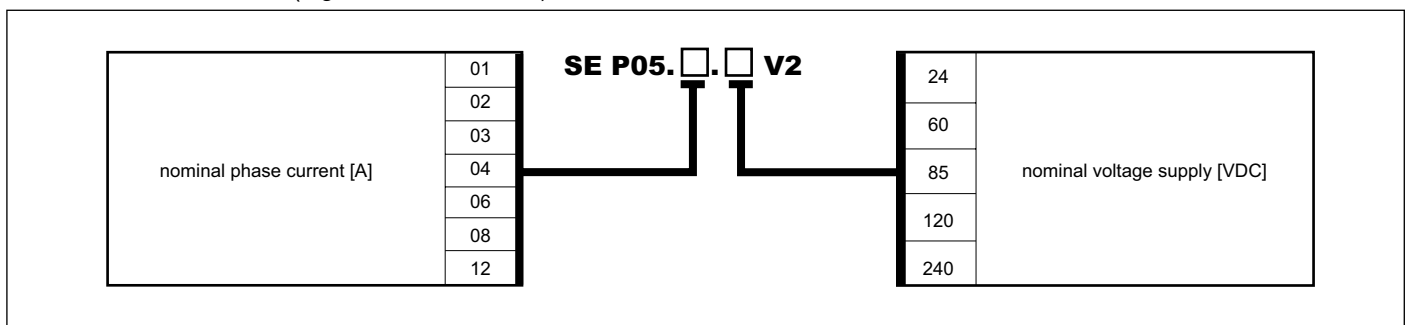

Restriction in possible combinations: 1A, 2A and 3A only with 24VDC and 60VDC, 240VDC only with 8A and 12 A

10 mains ready stepper motor power amplifier **WSE ...230AC V01**

General description

- Maximum power in smallest housing
- Compact metal housing also for small switch cabinets – available versions for DIN rail mounting and panel mounting
- Power amplifier with extremely low dissipation due to newest MOSFET-technology
- Cost effective system due to connection direct to the line (without isolated transformer) → 325VDC motor voltage
- Optimal with **STÖGRA** motor series SM 87, SM 88 and SM 107 (with new internal winding design suitable for 325VDC operation)
- The motor power at 2A and 325VDC is comparable with 8A / 80VDC at standard DC-supplied motor / amplifier systems, 4A and 325VDC compares to 12A / 110VDC, 6A and 325VDC compares to 12A / 160 VDC at standard systems
- Via DIP-switch selectable are different step angles from 200 to 12800 steps/revolution → micro stepping for true and smooth running of the motor
- Via DIP-switch adjustable phase current characteristics (2 different curves – sinus and damped sinus)
- Phase current adjustable via rotational switch from 0 to 4A / phase – at version WSE 06.230AC V01 from 0 to 6A / phase
- Easy connections via screw terminals and spring terminals at the front side for motor, mains and control signals
- Electronic protection against short circuit (motor and power amplifier), over temperature (power amplifier) and under voltage
- Output ready signal via relay contacts
- All input signals (pulse, direction, reset, boost, disable, switch step angle) are galvanically isolated via opto-couplers



Photos WSE 04.230AC V01:

- with connector,
- without connector,
- rear view with hut rail mounting clip

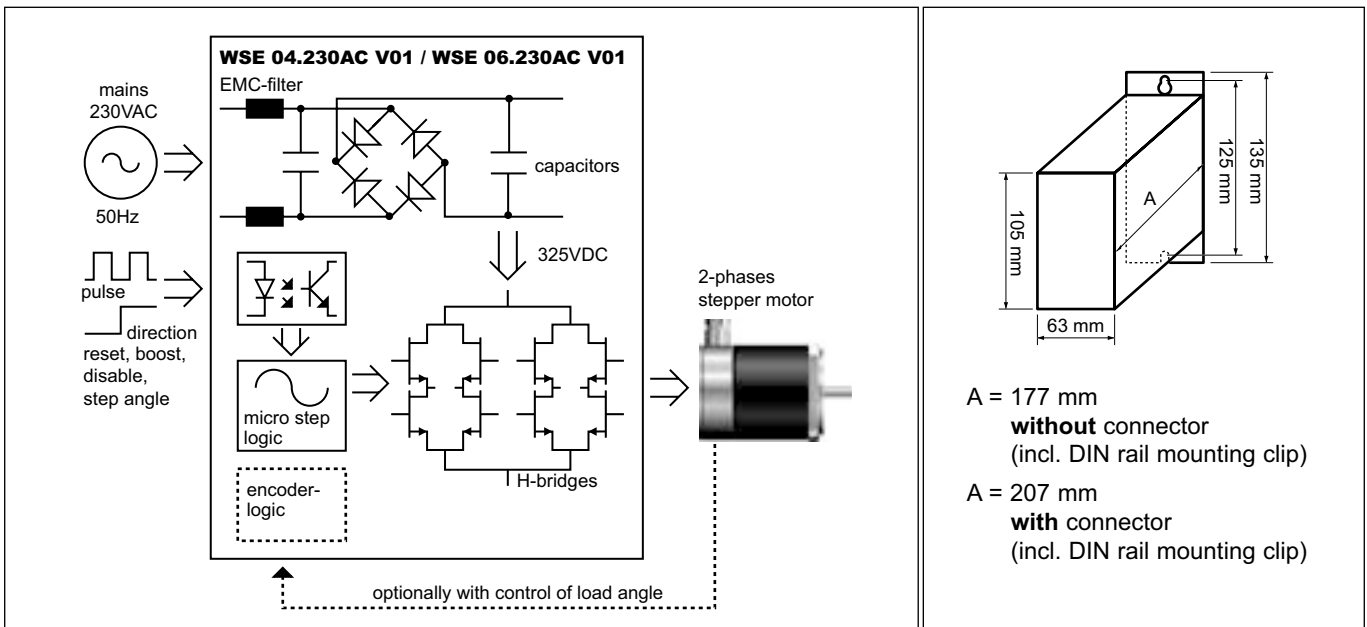

Stepper Motor specifications

Due to the internal motor voltage of 325VDC, all stepper motors operated with a WSE xx.230AC V01 power amplifier must include a sufficient insulation strength (motor winding insulation test voltage 2000VAC – 1s – according to VDE0530-1). STÖGRA stepper motors series SM 87, SM 88 and SM 107 with production date beginning from 2004 are motors with suitable insulation strength.

mains ready stepper motor power amplifier **WSE ...230AC V01** 11

Selection of step angle / resolution

Different step angles can be selected via the switches C0, C1, C2 and C3. With the input »angle« the step angle can be switched externally between two values (works only if switch »W« is open!).

During motion, switching the step angle is possible within the motor start-stop-frequency (when changing simultaneously the pulse frequency and step angle – at any frequency).

steps / revolution resolution externally switchable via the input »angle«		DIP-switch 3 to 6 for selection of steps / revolution X = ON, else = OFF			
input not active	input active	C0 (switch 3)	C1 (switch 4)	C2 (switch 5)	C3 (switch 6)
200	200	X	X	X	X
400	200	X	X	X	
500	500	X	X		X
800	400	X	X		
1000	500	X		X	X
1600	400	X		X	
2000	400	X			X
2500	500	X			
3200	800		X	X	X
4000	400		X	X	
5000	500		X		X
6400	400		X		
8000	500			X	X
10000	400			X	
10000	1000				X
12800	800				

for other step angles / resolutions please contact us

Double pulse (switch 7 »f x 2«)

If the switch 7 (f x 2) is ON, then each signal edge at the pulse input will result in the execution of a motor set (rising edges and falling edges will execute motor steps)

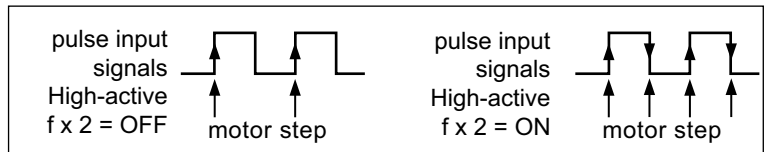

Automatical phase current reduction (switch 8 »R/2«)

If the switch 8 (R/2) is ON, then the phase current at motor standstill will be reduced by 50%. The first coming pulse will rise the phase current again to 100%. If a signal is active at the reset input, then the current reduction will not be activated.

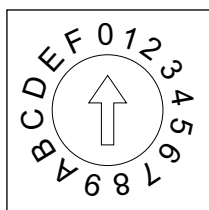

Phase current adjustment

Ex factory the power amplifier is set to 2A (WSE 04...) and 3A (WSE 06...). The phase current must be set to the bipolar phase current of the connected stepper motor. The adjustment is done via the rotational switch at the front side of the WSE according to below table. The table value corresponds to the bipolar phase current of the motor.

type / switch position	0	1	2	3	4	5	6	7	8	9	A	B	C	D	E	F
4 A/Ph. SE ...04...	0,00	0,27	0,53	0,8	1,07	1,33	1,6	1,87	2,13	2,4	2,67	2,93	3,2	3,47	3,73	4
6 A/Ph. SE ...06...	0,00	0,4	0,8	1,2	1,6	2	2,4	2,8	3,2	3,6	4	4,4	4,8	5,2	5,6	6

Input- / Output signals description

- Boost:** phase current is increased by 20%
- Disable:** phase current in the motor phases will be shut off
- Reset:** Drive errors are reset, drive in reset position (phase zero), pulse signals are disabled
- Dir:** Control of motor direction
- Clk:** Each pulse executes one motor step
- Angle:** The step resolution will be changed – see step angle / resolution table above
- Ready signal:** An **electrical error** (under voltage, short circuit or over temperature) or a **mechanical error** (only E50 versions) will open the relay contact. Other wise the relay contact is closed (ready for operation)

12 mains ready stepper motor power amplifier **WSE ...230AC V01**

Input signals

Signal rise time max.: 1µs, signal fall time max.: 1µs, frequency pulse max.: 200 KHz

input signals HIGH-active

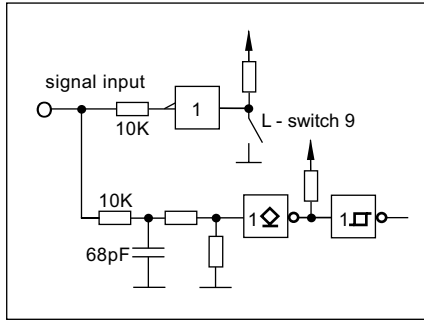

input signals SPS – level

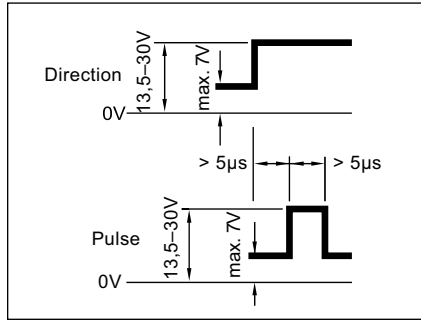

input signals TTL – level

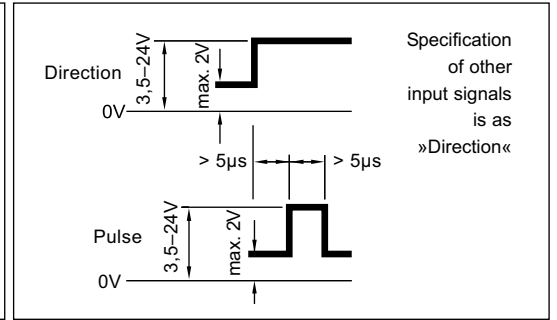

Input signals – adjustment signal level – switch »SPS« and »L«

signal specifications	switch »L«	switch »SPS«	connection »Clk« and »Dir« at signal plug port
High-active TTL	OFF	OFF	Clk- and Dir- (Clk+ and Dir+ are not connected)
High-active SPS	OFF	ON	Clk- and Dir- (Clk+ and Dir+ are not connected)
Low-active	ON	OFF	Clk+ and Dir+ (Clk- and Dir- are not connected)
not valid	ON	ON	
RS422	OFF	OFF	Clk+ and Clk- and Dir+ and Dir- (all other signals High-active SPS)
RS422	OFF	ON	Clk+ and Clk- and Dir+ and Dir- (all other signals High-active TTL)

In case of set modes »High-active« and »Low-active« the connection »GND« has to be connected with the control sending the signals »Clk« and »Dir«.

In case of a set mode »RS422« the connection »GND« has to be connected only in case other signals than »Clk« and »Dir« shall be used additionally.

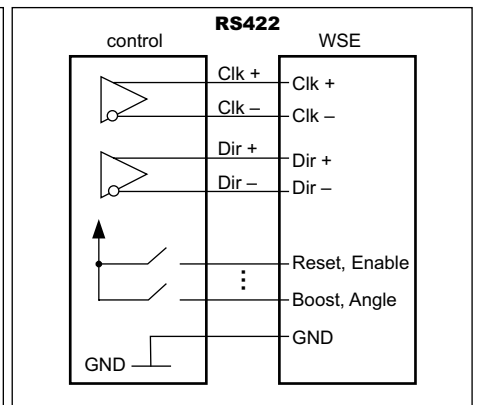
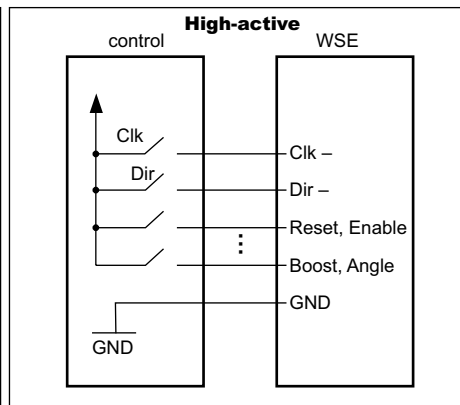
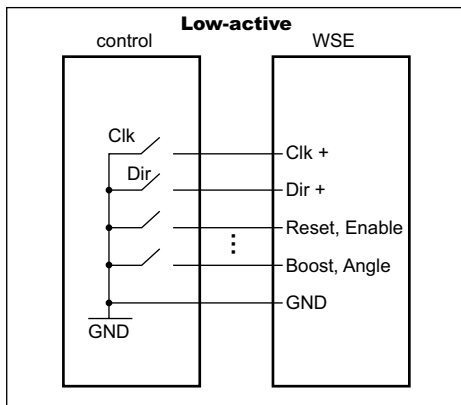

Output-ready signal

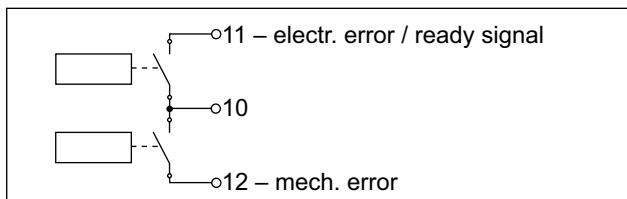

output signal

Voltage supply

WSE ... 230AC V01: 230 VAC / 50 – 60 Hz
Internally 325VDC are created (motor voltage)

WSE ... 115AC V01: 115 VAC / 50 – 60 Hz
Internally 162VDC are created (motor voltage)

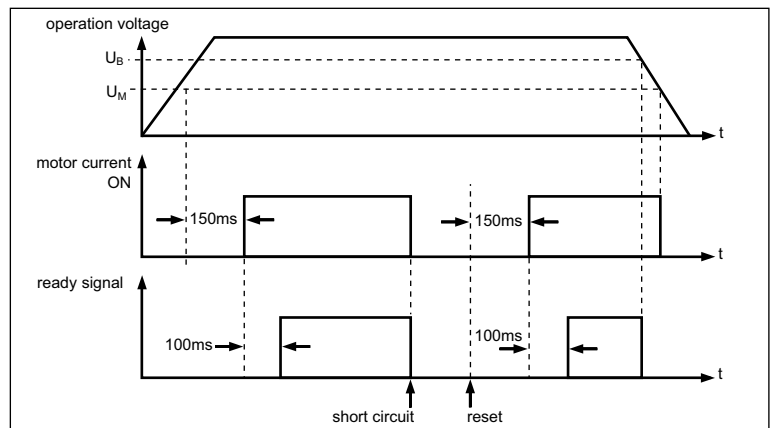

Timing output-ready signal

mains ready stepper motor power amplifier **WSE ...230AC V01** 13

Connections

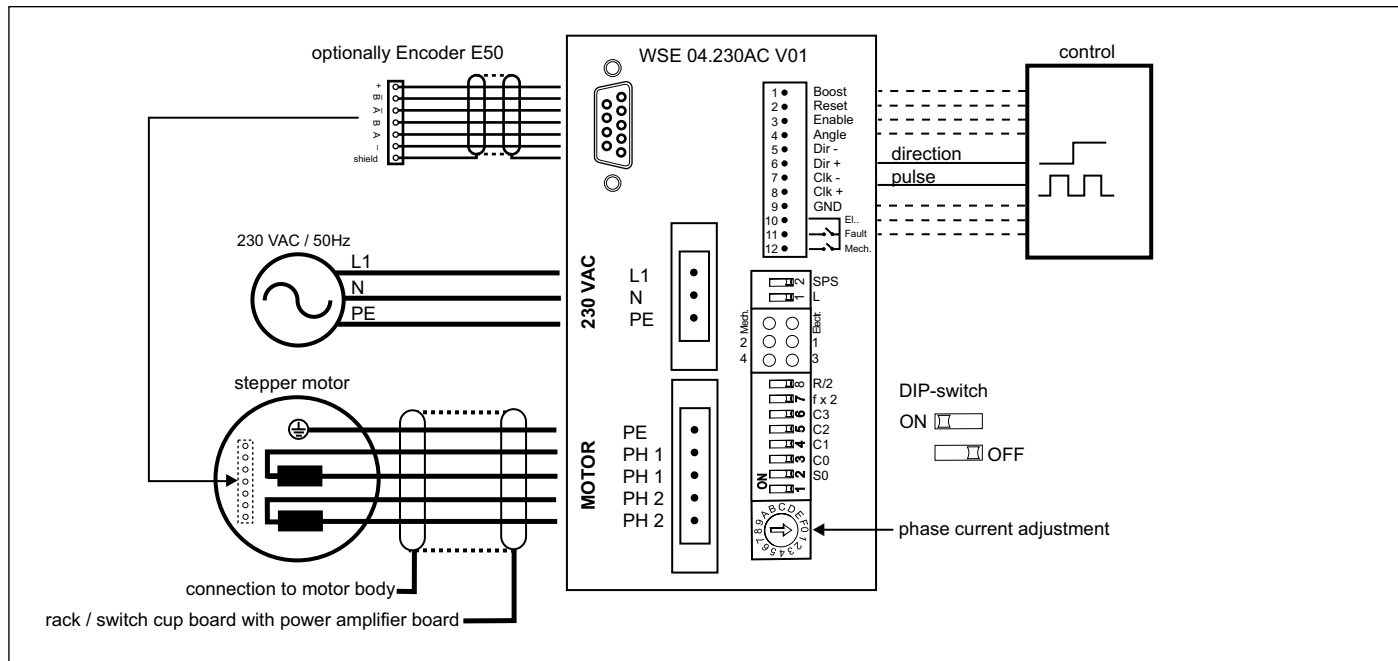

All inputs not used may stay open – it is not necessary to connect them to an external potential.

Pulse and direction are used for a normal stepper motor operation (there is no need to connect the pulse direction signal, if the motor shall run only into one direction).

All other inputs at the signal port may be connected according to the applications requirements.

Technical specifications

protection of device	protection IP20, protection against short circuit, overtemperature und undervoltage	
weight	nominal current	4 A/Ph 6 A/Ph
	weight	0,9 Kg 0,9 Kg
ambient conditions	ambient temperature: 0°C to 50°C, max. housing temperature: 85°C	
noise imunity	in case of correct installation: according to EN50082-2: – at selectedi TTL-signal the inputs are not imune against fast transients (Burst)	
noise radiation	In case of correct installation and shielding or / and filtering of the lines and signals according to EN55011 class B	
RoHs conformdirective to 2002/95/EC		

Available versions: (e.g.: WSE 04.230AC V01, WSE 06.115AC V01/W, WSE 06.230AC V01, ...)

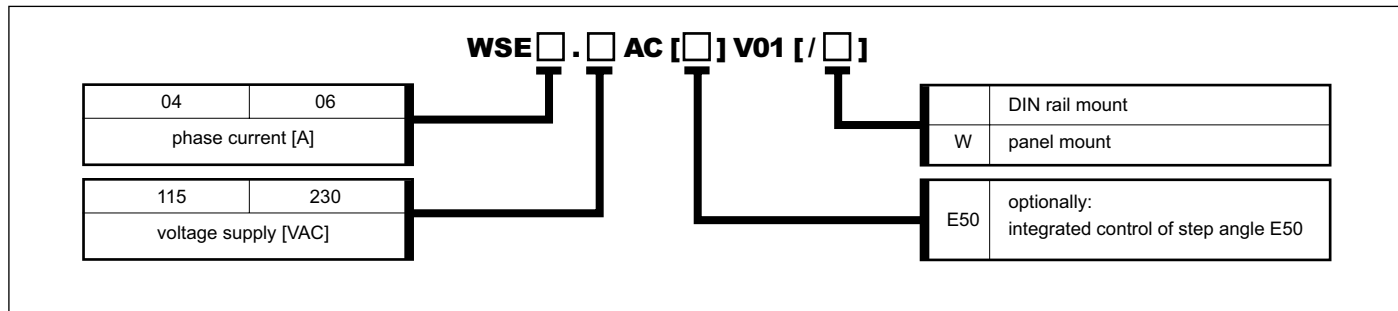

14 stepper motor power amplifier **WSE 04.80 V01 / WSE 08.80 V01**

General notes

- Microstepping power amplifier with bipolar chopper for 2-phases stepper motors
- Maximum power integrated in smallest housing
- Compact metal housing fits also in small switch cabinets
- Available as DIN rail mounting version or panel mounting version
- Extremely low dissipation due to newest MOSFET-technology
- No forced draft necessary
- Wide range of voltage supply from 20 to 80VDC
- Phase currents adjustable via 16 stage rotative switch from 0 to 4A/phase (WSE 04...) or 0 to 8A/phase (WSE 08...)
- Optimal with **STÖGRA** motor series SM 56, SM 87, SM 88 and SM 107
- 16 different step resolutions between 200 and 12800 steps/revolution selectable via DIP-switches
⇒ micro stepping for optimal, smooth true running of the stepper motor
- The step resolution can be switched between two values via an external input during the motor is running
- Easy connecting via front side screw terminals and spring terminals for all lines and signals
- Electronical protection against short circuit (motor phases), over temperature (power amplifier) and under voltage
- Output ready signal via relay
- Input signals (pulse, direction, reset, boost, disable, change step angle) optionally opto-coupler isolated
- Adjustable input signal level: Low-active, High-active TTL (5V), High-activ PLC (24V), or RS422 (only pulse and direction)



Photos WSE 08.80 V01:
 • with connectors,
 • without connectors,
 • rear view with DIN rail mounting clip

Photo WSE 04.80 V01/W:
 for panel mounting

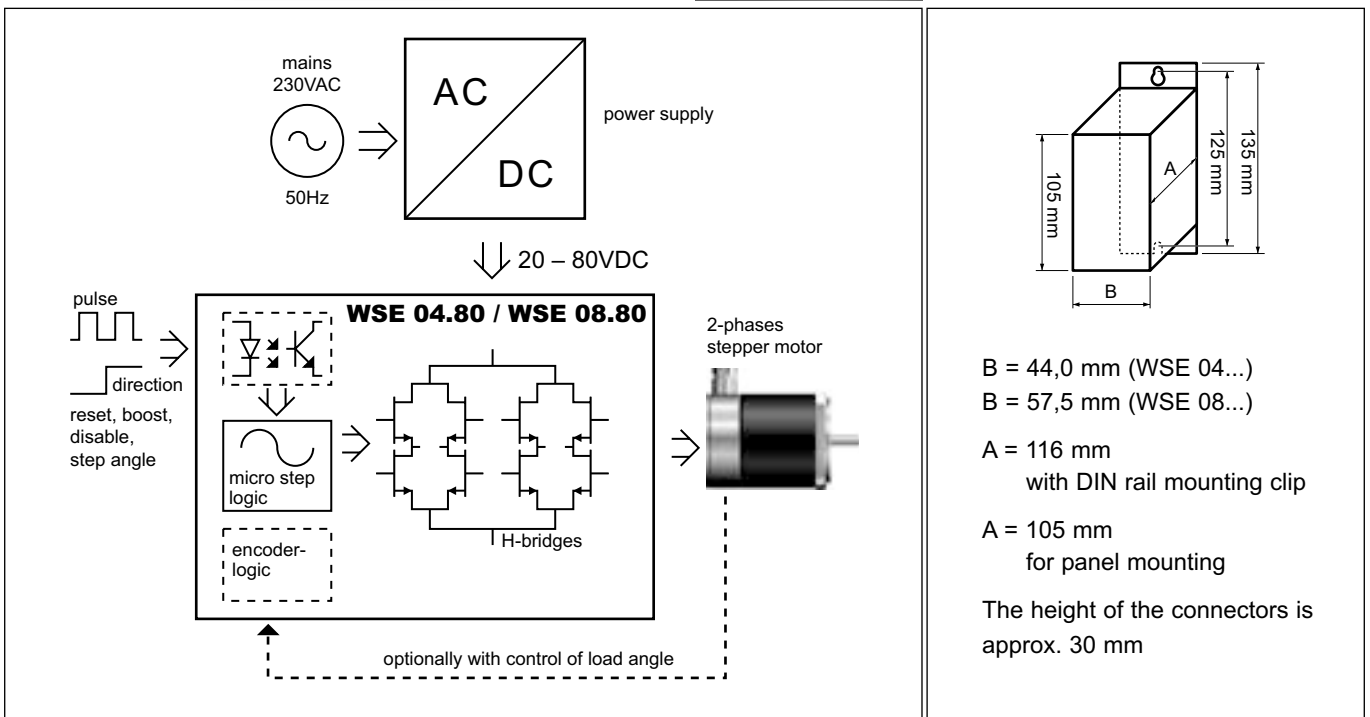

Configurations via DIP switches

switch	remarks	standard adjustments
1	no function	OFF
2 (S0)	phase current characteristics ON: SM87/SM88 OFF: SM107	ON: SM 87/SM88
3 (C0) – 6 (C1)	step angle adjustmens – see step angle-table	OFF: 12800 steps / revolution
7 (f x 2)	double step	OFF: no double step
8 (R/2)	current reduction at standstill ON: I = 100% OFF: I = 50%	ON: no current reduction
9 (L)	signal level input – low active / high active	OFF: High active
10 (SPS)	signal level input – TTL-level / SPS-level	OFF: TTL

Voltage supply: 20 – 80VDC, ripple max. 5%

Phase current: adjustable for 0 – 4A/phase and for 0 – 8A/phase (adjustment as WSE...230AC)

All other dates and adjustments as WSE ... 230AC V01 (see page 8 to 13)

Connections

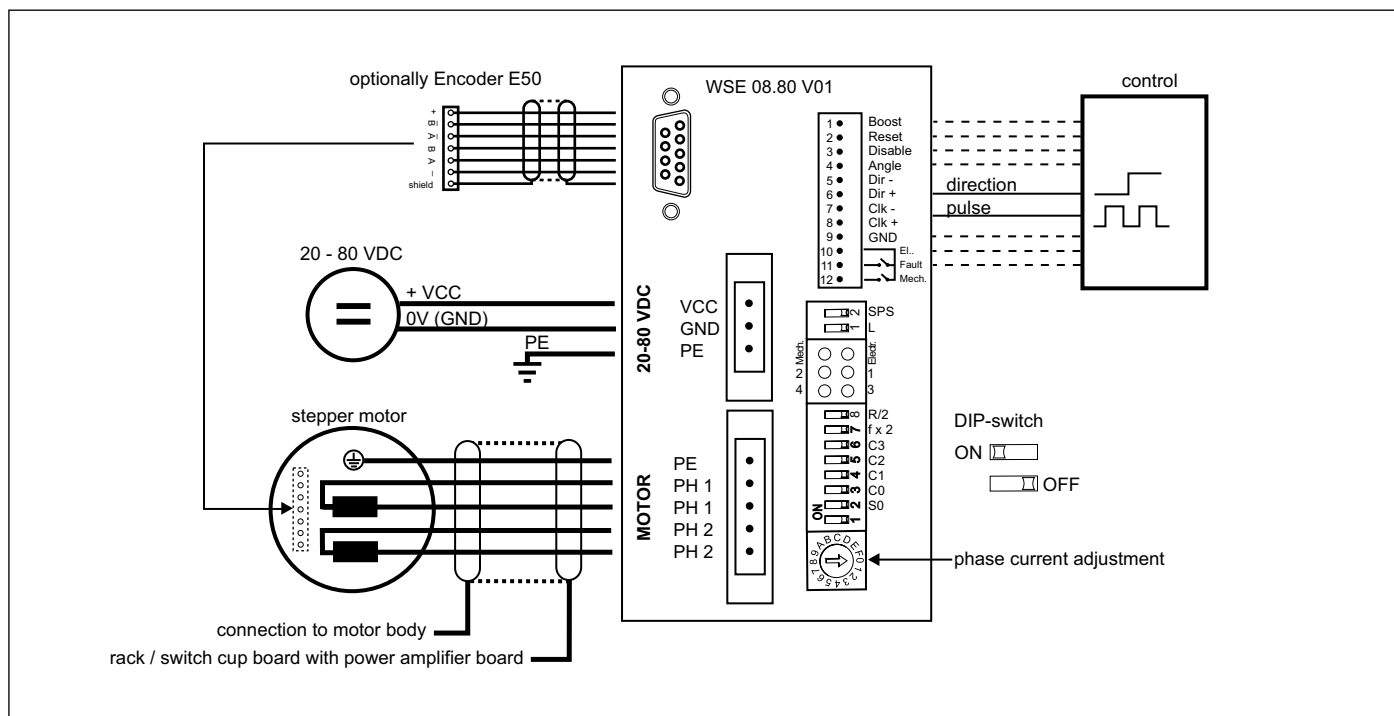

Available versions: (e.g.: WSE 08.80 V01, WSE 08.80 V01/G, WSE 08.80 V01/W, WSE 08.80 V01/WG, ...)

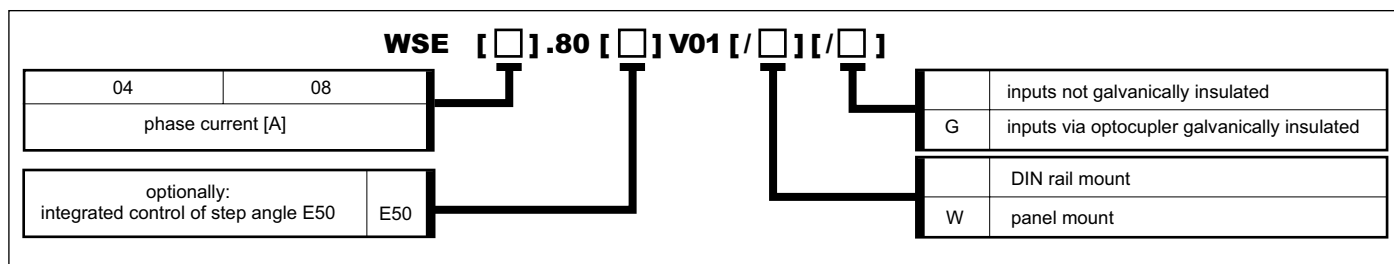

16 STÖGRA power supplies

NT-power supplies are non stabilized voltage supplies. A power supply includes an isolated transformer, bridge rectifier, electrolytical capacitors, fuses, PTC for limiting the switch-on-current and it is mounted on an aluminium-mounting plate.

A discharging circuitry ensures, that the capacitors are discharged within 5s after disconnecting the power supply from the mains.

All connections are via screw terminals.

Multiple control amplifier boards may supplied by one NT-power supply, depending on total power needed.

The calculation of a power supply depends on motor operation – by taking into consideration the maximum load current for the motor (which also depends on the motor speed) and the duty cycle of the motor.

The protection class of the power supplies is IP00, therefore they must be mounted in a closed switch cabinet.

type	power	Einschaltdauer ED	input	output	weight
NT 350	350 VA	100%	230 VAC 50/60 Hz	24, 36, 60, 85 or 120 VDC	4,4 Kg
NT 500	500 VA	100%	230 VAC 50/60 Hz	24, 36, 60, 85 or 120 VDC	5,4 Kg
NT 1000	1000 VA	70%	230 VAC 50/60 Hz	60, 85 or 120 VDC	7,9 Kg

Power supplies with output 120VDC include a 60VDC and a 120VDC output.

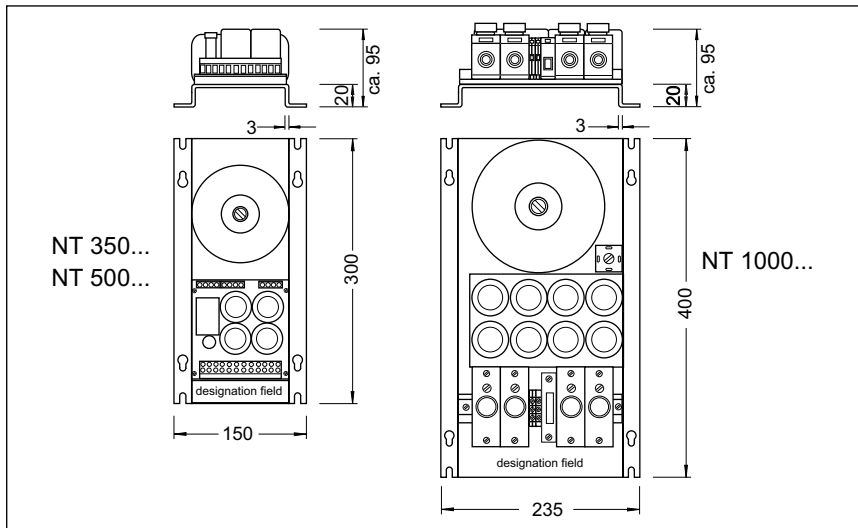

Dimensions NT



Power supply NT500.120

Power supply ordering key:

Example: The order number of a power supply with output 120VDC and 500VA power is NT 500.120

Power supplies for input 115VAC/60 Hz mains supply are available, to (ordering code for 500VA and output 120VDC is NT 500.120 / 115VAC)

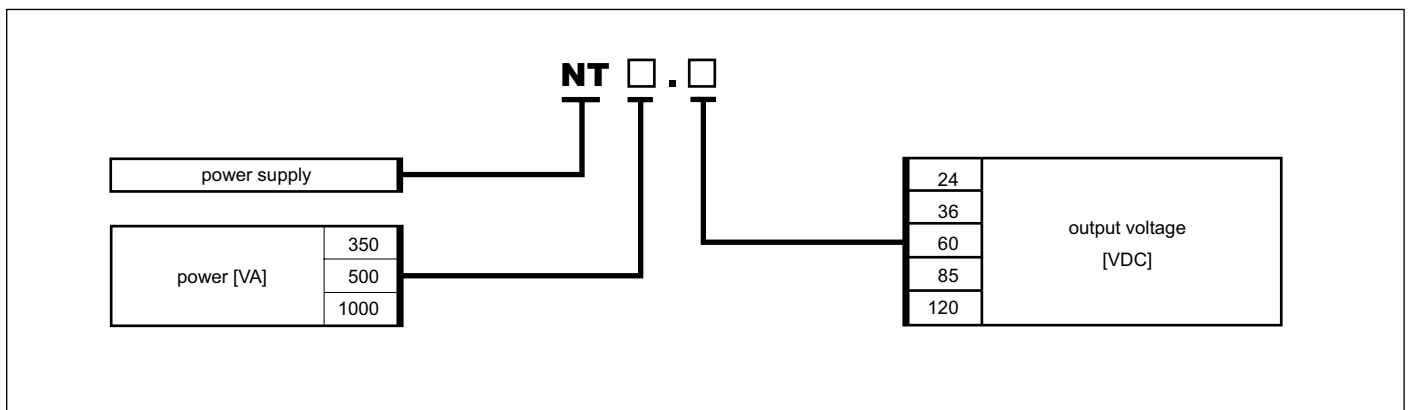

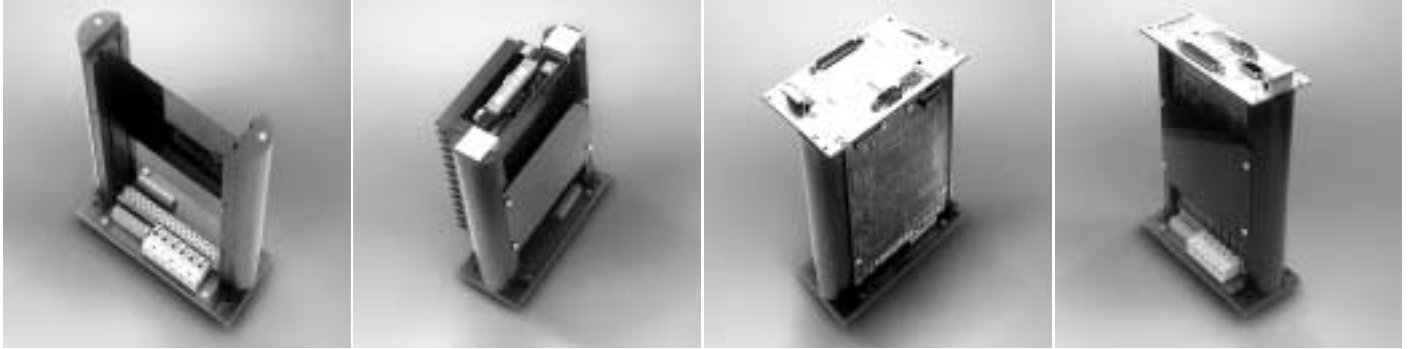

Board holder KH-SE_01

KH-SE_01 with SE P05.06.85 V2

KH-SE_01 with SERS 06.85 V04 H

KH-SE_01 with SERS 02.24 V04 E50

- Low cost plug board holder for all **STÖGRA** power amplifier boards series SE... and position controls series SERS... with 32-pole connector
- Easy mounting in switch cabinets
- Quick replacing of boards
- Ideal also for laboratory test operation
- All connections via screw terminals
- Robust design with screwed mounted PVC devices

Dimensions

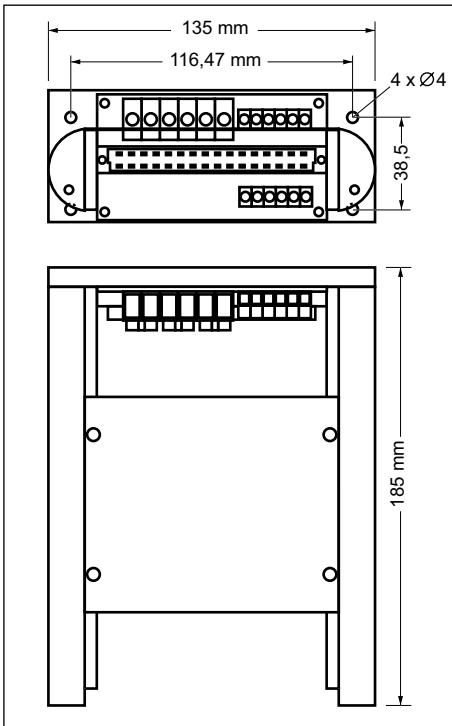

Connections

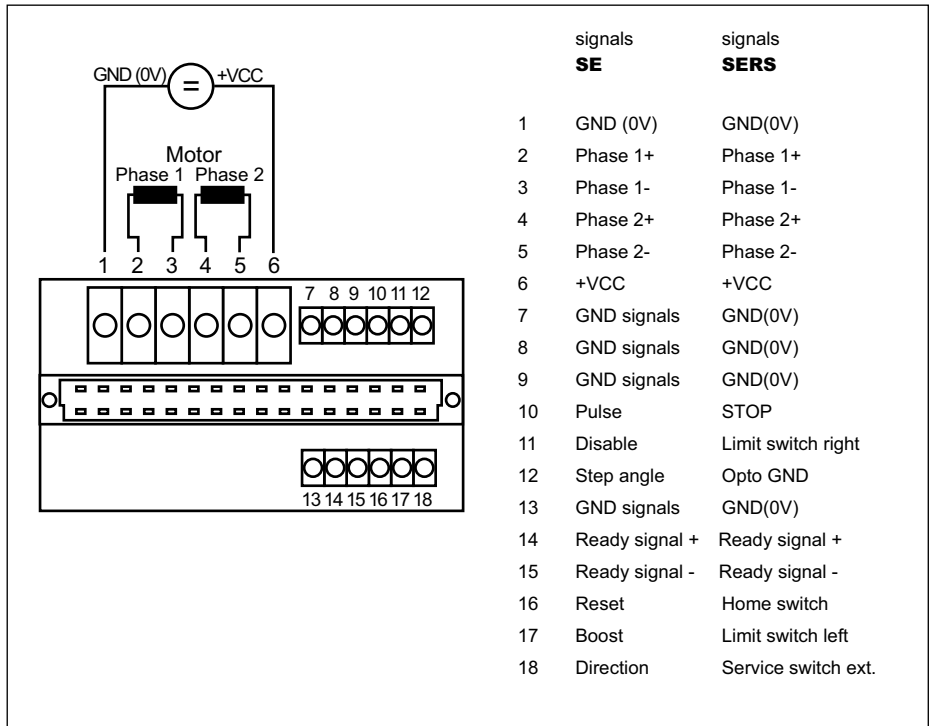

Front panels for power amplifier boards series SEE ...V3.. and SEE P05...V2



- Front panels (16 TE) mounted on SE boards for using in ELK/ELR racks
- The SE-board LEDs can be seen and all switches can be operated from the front side
- ELK and ELR-racks with SE boards are closed at the front side by using the front panels (protection class IP20)

Ordering key:

SE...V3.. boards with front panel must be ordered as **SEE ... V3..**

SE P05 ...V2 boards with front panel must be ordered as **SEE P05...V2**

(an additional »E« must be placed after the first »SE« → SEE...)

18 STÖGRA panel mount / 19 inch-systems series ELK / ELR

The panel mount / 19 inch rack system series ELK/ELR is a mains ready single or multiple axis stepping motor control which can be mounted e.g. in a switch cabinet and can be connected easily via screw terminals. ELK/ELR-systems include plug ports for STÖGRA amplifier boards series SE...[E50] V31/V33 with 32-pole connector VG (DIN 41612 type D) or position controls series SERS.

Each power amplifier plug port additionally includes a plug port for a fan board. In that way fans can be installed easily also afterwards.

All connections (mains, motor and control signals) are via screw terminals or spring terminals (signal connections at ELR racks). ELK/ELR racks are available with and without integrated power supply (connection to 230VAC/50Hz – also available for 115VAC/60Hz). All ELK-/ELR-racks with power supply include in standard version a second (galvanical isolated) 24VDC output.



ELK... front side

ELR... rear side

ELR... front side

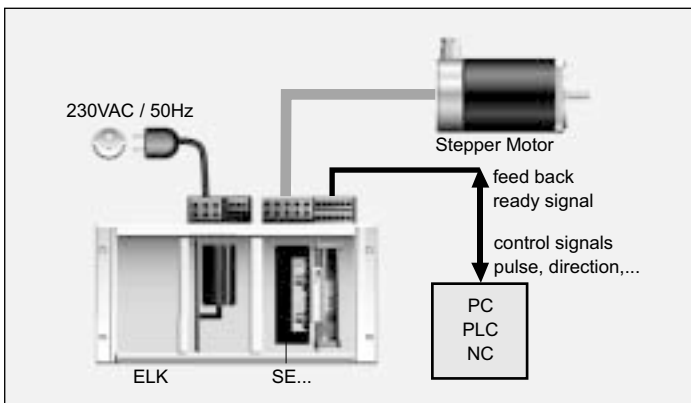

ELK... with SE...front side

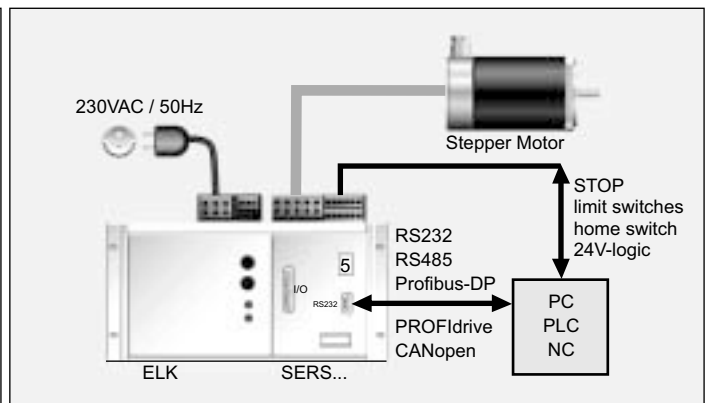

ELK... with SERS front side

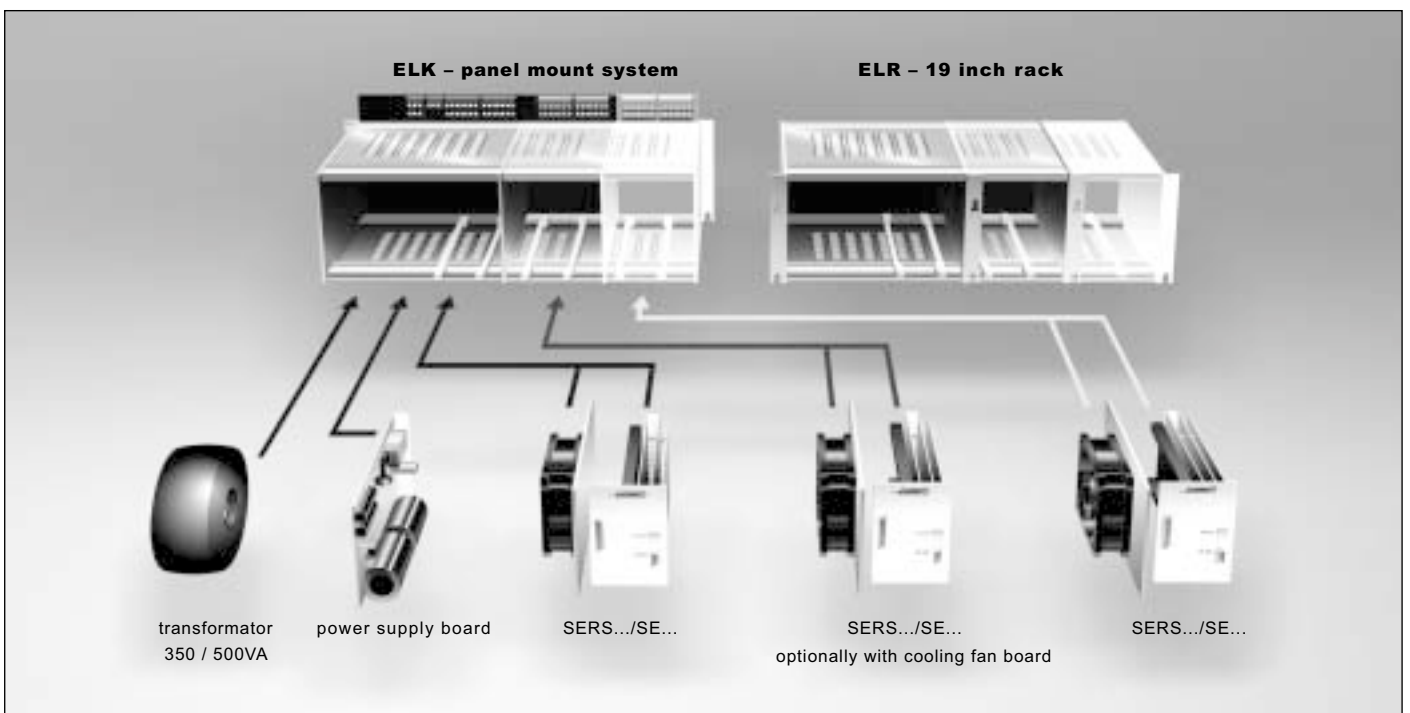

STÖGRA panel mount / 19 inch-systems series ELK / ELR 19

ELK and ELR for SE... or SERS...

ELK...S and ELR...S for SE... or SERS...S with max. 4A phase current / 60VDC voltage supply

Other available versions for ELK- and ELR-racks:

- Less plug ports than physically possible in the rack → e.g. ELR4.n.u.1 (ELR4.350.60/24.1)
→ 19 inch rack ELR4 with power supply and only 1 plug port for SE or SERS
- External connections for motor voltage supply option »E« also for ELK-/ELR-racks with power supply
→ e.g. ELK4.500.85/24/E.3 A3
for common voltage supply of multiple ELK-/ELR-racks via one power supply integrated in one of the ELK-/ELR-racks
- ELR-rack ELR1, ELR2 and ELR3

20 STÖGRA panel mount / 19 inch-systems series ELK / ELR

ELK dimensions and connections

Dimensions: 8.15, 10.3 x 6.8, 57.15, 132.5, 157, 192.

	A	B
ELK 1	158	118
ELK 2	270	230
ELK 3	376	336
ELK 4	483,5	443,5

SE...

- 5 ready signal (+)
- 6 pulse
- 7 disable
- 8 step angle
- 9 GND
- 10 24VDC
- 11 ready signal (-)
- 12 reset
- 13 boost
- 14 direction
- 15 GND
- 16 24VDC

SERS

- ready signal (+)
- Stop switch
- limit switch left
- opto GND
- GND (24VDC)
- 24VDC
- ready signal (-)
- home switch
- limit switch right
- service switch ext.
- GND (24VDC)
- 24VDC

Connection diagrams for L1, N, PE, GND (24VDC), GND (VCC), PE, phase 1, phase 2, and screw terminals.

ELR dimensions and connections

Dimensions: 8.15, 10.3 x 6.8, 57.15, 132.5, 185, 205.

	A	B
ELK 1	158	118
ELK 2	270	233
ELK 3	376	336
ELK 4	483,5	446,6

Connection diagrams for L1, N, PE, GND (24VDC), GND (60VDC), +VDC, 0V GND, phase 2 -, phase 2 +, phase 1 -, phase 1 +.

interface for SERS with option R1 or R2 connection RS232 R 9-pole D-Sub-connector

- Pin 1
- Pin 4
- Pin 5
- Pin 7
- Pin 8
- Pin 9

I/O-signals for SERS with option R1 or R2

- 24VDC
- VCC OUT
- GND OUT
- GND (24VDC)
- 24VDC
- GND IN
- GND (24VDC)
- ADC neg
- ADC pos
- 11
- O4
- O3
- O2
- O1
- 18
- 17
- 16
- 15
- 14
- 13
- 12
- 16
- 15
- 14
- 13
- 12
- 10
- 9
- 8
- 7
- 6
- 5
- 4
- 3
- 2
- 1

SE...

- 5 ready signal (+)
- 6 GND (VCC)
- 7 pulse
- 8 disable
- 9 step angle
- 10 GND (24V)
- 11 ready signal (-)
- 12 GND (VCC)
- 13 reset
- 14 boost
- 15 direction
- 16 +24VDC

SERS

- ready signal (+)
- GND (VCC)
- Stop
- limit switch left
- Opto-GND
- GND (24V)
- ready signal (-)
- GND (VCC)
- home switch
- limit switch right
- service sw. ext.
- +24VDC

STÖGRA panel mount / 19 inch-systems series ELK / ELR 21

ELK ...S connections

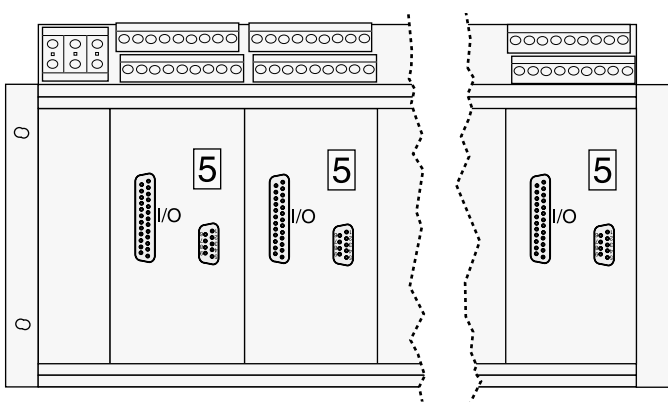

SE...	SERS...
1: PE / Shield	1: PE / Schirm
2: Motor phase 1	2: Motor Phase 1
3: Motor phase 2	3: Motor Phase 2
4: Ready signal	4: Ready signal
5: Pulse	5: STOP
6: Disable	6: Limit switch left
7: Step angle	7: Opto-GND
8: GND	8: GND (24VDC)
9: +24VDC	9: +24VDC
11: PE / Shield	11: PE / Shield
12: Motor phase 1	12: Motor phase 1
13: Motor phase 2	13: Motor phase 2
14: Ready signal	14: Ready signal
15: Reset	15: Home switch
16: Boost	16: Limit switch right
17: Direction	17: Service switch extern
18: GND	18: GND (24VDC)
19: +24VDC	19: +24VDC

ELR ...S connections

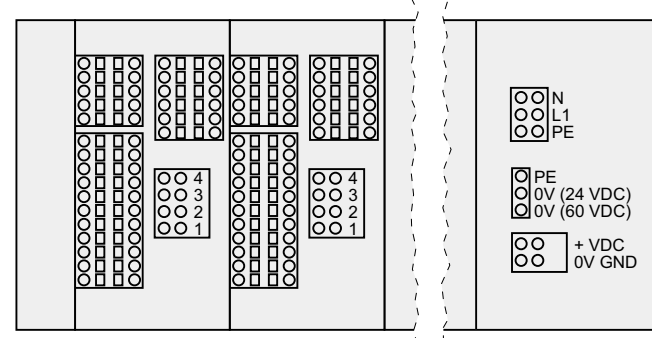

connection	SE...	SERS
5	Ready signal (+)	Ready signal (+)
6	GND (VCC)	GND (VCC)
7	Pulse	STOP
8	Disable	Limit switch left
9	Step angle	Opto-GND
10	GND (24V)	GND (24V)
11	Ready signal (-)	Ready signal (-)
12	GND (VCC)	GND (VCC)
13	Reset	Home switch
14	Boost	Limit switch right
15	Direction	Service sw. ext.
16	+24VDC	+24VDC

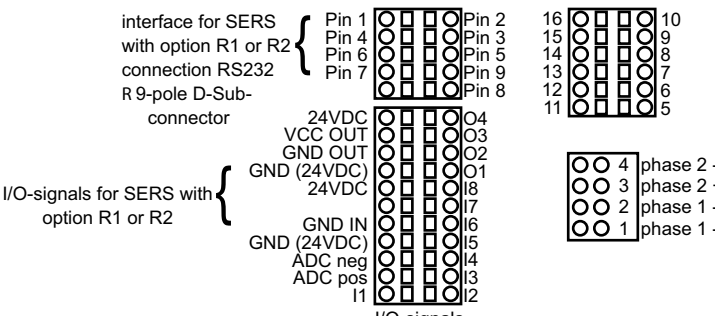

interface for SERS with option R1 or R2 connection RS232 R 9-pole D-Sub-connector

- Pin 1
- Pin 4
- Pin 6
- Pin 7

24VDC VCC OUT GND OUT GND (24VDC) 24VDC

GND IN GND (24VDC) ADC neg ADC pos 11

I/O-signals

Pin 2 Pin 3 Pin 5 Pin 9 Pin 8

16 15 14 13 12 11

10 9 8 7 6 5

O4 O3 O2 O1

18 17 16 15 14 13 12

4 phase 2 - 3 phase 2 + 2 phase 1 - 1 phase 1 -

22 STÖGRA panel mount / 19 inch-systems series ELK / ELR

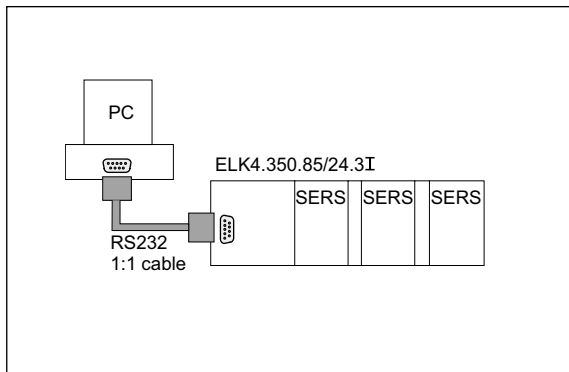

Option »I« for ELK (for SERS with RS232):

Common interface connection for all SERS in a ELK-rack
– when connecting an ELK-rack with SERS units to one common RS232-interface of a PC.

Connection PC-ELK via a 1:1 cable.

The SERS boards must be ordered with option R4.

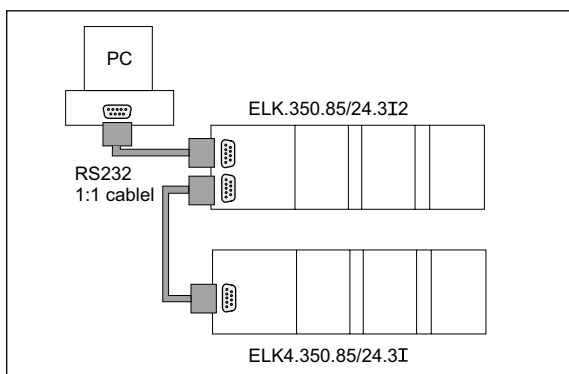

Option »I2« for ELK (for SERS with RS232):

2 common interface connections for all SERS in a ELK-rack

→ RS232 – input and output when connecting multiple ELK-racks with SERS at one common RS232-interface of a control (e.g. PC).

Connection PC-ELK-ELK is via 1:1 cabel.

SERS must be ordered with option R4.



ELK2.350.85/24.1 P with SERS 06.85 V04 R4

Option »P« for ELK or ELR for integrating a SERS-Programmer into the rack (at front side):

The SERS-Programmer must be ordered separately.

When using ELK-racks the SERS boards must be ordered with option R4 or R5, when using ELR-racks the SERS boards need option R1 or R2.

Option S: Small plug ports for SERS...S position controls or SE 01.. / SE 02.. / SE 03.. / SE 04.. (until 60VDC) power amplifier boards.

Option V: For using with SE ... power amplifier boards (for standard SERS position controls do not order option »V«) or for using with SERS position controls with option »U« (seperate 24V logic supply)

Option E: Connection for external supply of the motor supply DC voltage (for ELK-racks without power supply) respectively for the DC voltage supply of other ELK-racks without power supply

Cover of ELK / ELR racks:

Top side and bottom side: Aluminium plates with air ventilation slots.

Rearside: ELK-racks with 10 mm PVC plate

Front side: SERS-boards in standard version with front panels – SE-power amplifier boards without front panels

STÖGRA panel mount / 19 inch-systems series ELK / ELR 23

Technical specifications:

protection class	protection class IP20		
weight	type	ELK / ELR with power supply	ELK / ELR without power supply
	weight	6,2 kg – 7 kg (depending on version)	1,8 kg – 2,6 kg (depending on version)
RoHs conformdirective to 2002/95/EC			

ELK/ELR ordering key

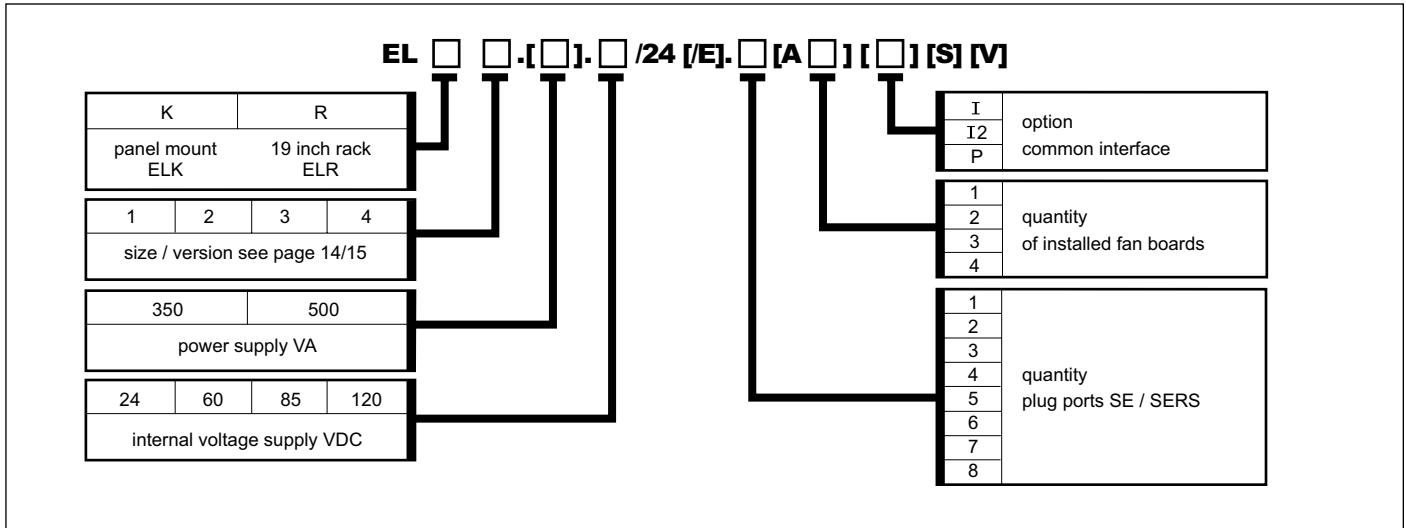

Ordering examples: ELK2.350.85/24.1 V ELK3.500.120/24.2 A2 I ELK3.60/24/E.5 I2 S ELR4.350.85/24.3 A3 P

24 Position control – series SERS

The stepping motor position control series SERS controls 2-phases stepping motors. A unit consists of a power amplifier, a microstepping power amplifier control and the position control. The communication with the position control is via an interface RS232C/V24, RS485, Profibus-DP, PROFIdrive, CANopen (DSP 402).

The SERS guarantees an optimal, free of vibrations true running due to its microstepping operation with 12800 steps/revolution and the possibility to select different phase current characteristics to match the characteristics of the used stepping motor type. The rough step by step operation of conventional stepping motor drives at low speed ranges has been improved extremely by the SERS to a very smooth running (comparable with servo motors). In standard version the SERS can be operated in four different modes:

Serial operation

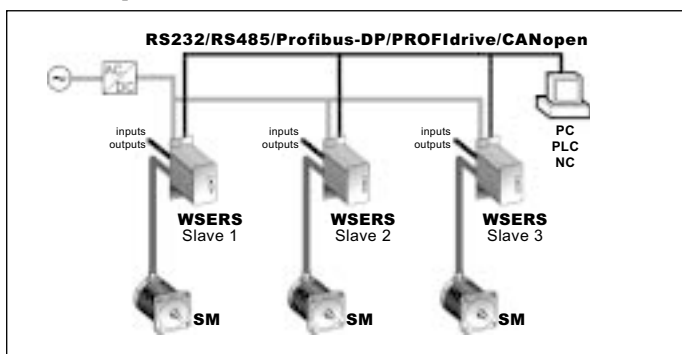

Operation with PC/PLC/NC as higher order control (master) and communication via a fieldbus / serial interface with SERS-slaves

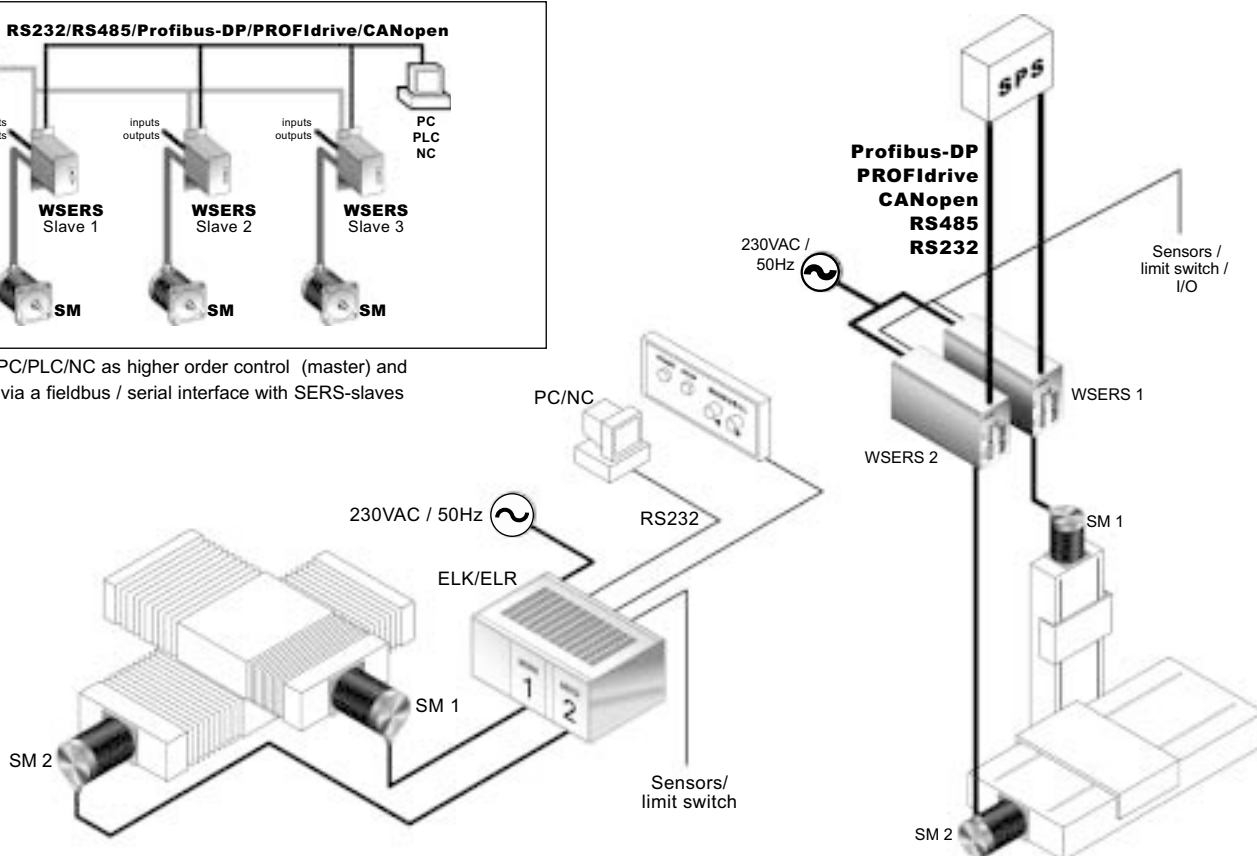

Standalone operation

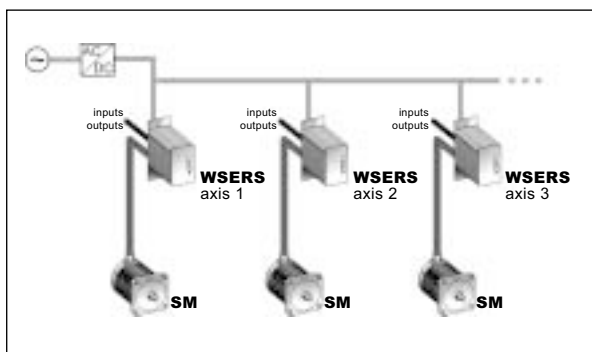

Operation with SERS-slaves as independent working axis, with stored operational programs, controlled by events at the digital inputs – e.g. manual start switch, limit switch, light barriers.

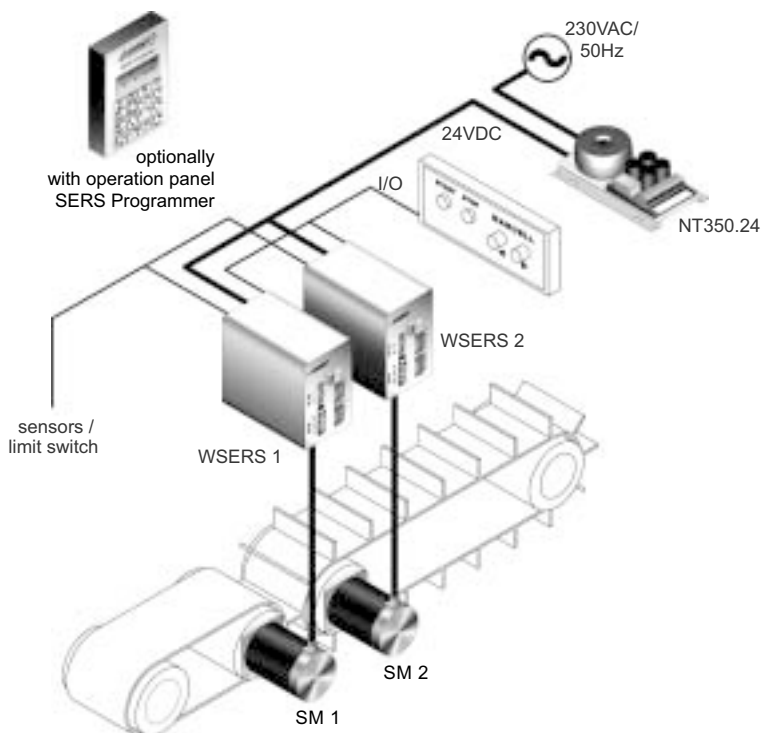

Parallel (BCD) operation

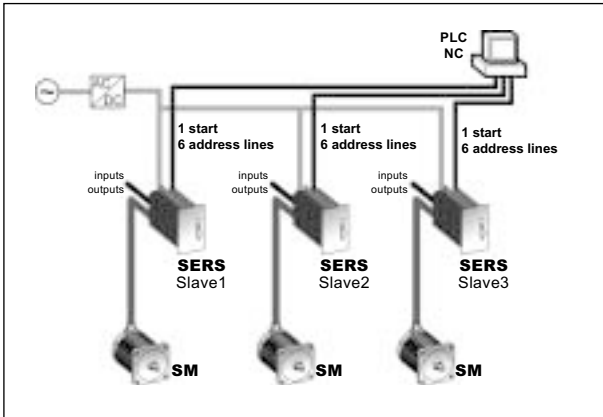

Operation with a PLC/NC or simple switches as higher order control, which call and start different operational programs in the SERS via the digital-parallel inputs (binary mode). Up to 64 different operational programs per SERS can be called.

Master operation

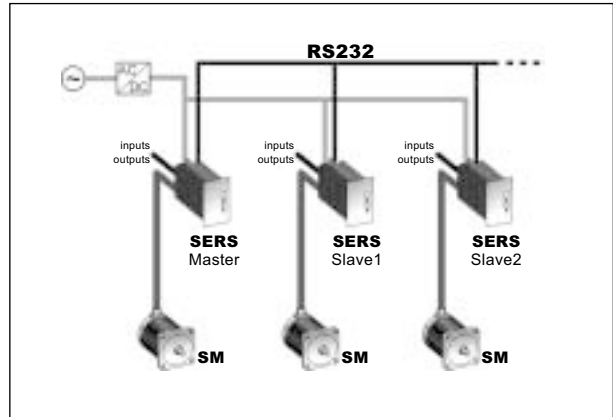

Operation with a SERS as higher order intelligent control (master), which controls other SERS-slaves via the serial interface.

No other (higher ranking) control necessary!

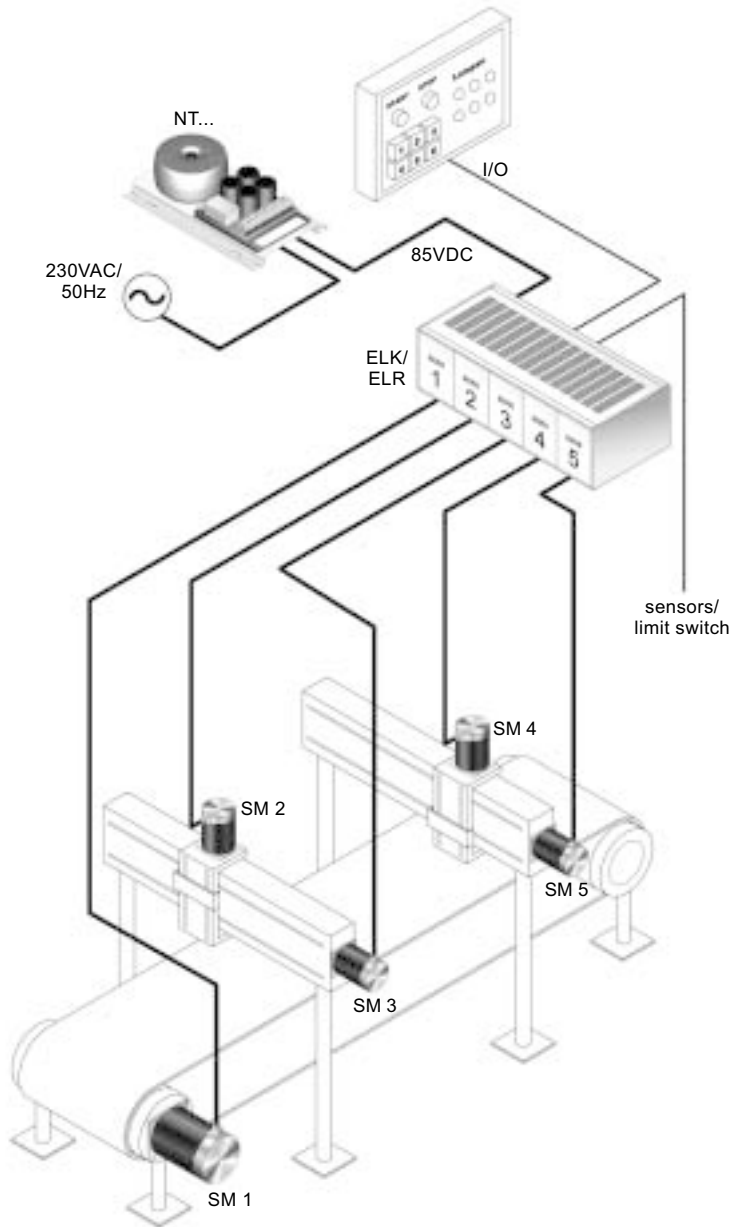
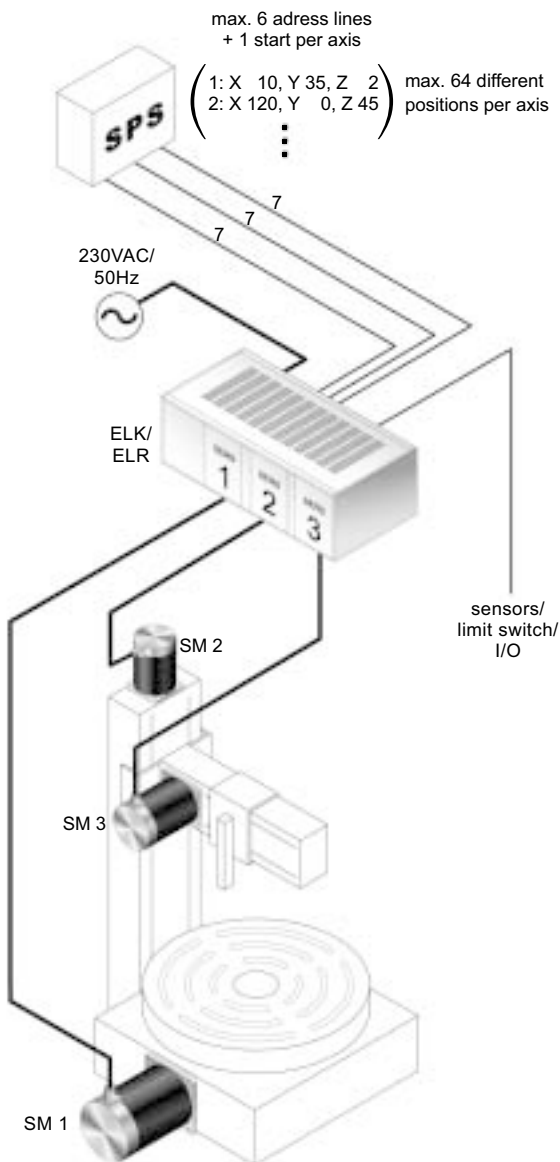

26 Position control – series SERS

Overview functions and specifications:

Power amplifier:

- excellent truth running because of **microstepping operation at 12800 steps/revolution** and four different phase current characteristics, which can be selected for matching different stepping motor types
- **phase current from 0 to 14,5A/phase, depending on version, programmable via interface**
- **power supply** depending on version 24 until 240 VDC
- protection against short circuit, over temperature and under voltage, additional pre-warning of temperature and under voltage

Inputs and outputs:

- **8 digital inputs, configurable low-/high-active (pull up or pull down input resistors), TTL (5V) or PLC (24V) – signal level**
- **2 limit switch inputs and 1 home switch input and 1 STOP switch input**
– optoisolated for 24VDC signal level
- **4 digital outputs**, each max. 500 mA / 24VDC
– optoisolated for external 24VDC supply and protected against short circuit
- **1 potential free output** – relay max. 100mA / 24VDC – usable e.g. as ready signal
- **1 analogue input** – 8 Bit, 0 to 5VDC
- Optional I/O – **extension: additional 8 digital inputs and 12 outputs**
(each max. 100mA / 24VDC)

Optionally step angle control / connection of hand wheel / electrical gearing function

- **control of motor step angle**, together with a two channel encoder (signals A, A̅, B, B̅) mounted on the motor
– 5VDC or 24VDC encoders
- **closed position loop** – lost steps (because of mechanical overload at motor) can be corrected
– encoder controls real motor position
- connection of a **hand wheel** (with 2-channel encoder signals), via the optionally encoder evaluation logic, or via two digital standard inputs

Interface:

- **RS232C/V24 (standard-PC COM-interface)**, with or without hardware handshake (selectable by software), **RS485, Profibus-DP/V0, PROFIdrive or CANopen**
- via DIP-switch adjustable baudrate from 2400 to 115200 Baud (RS232 and RS485) and drive address from 0 to 127
Profibus with baud rate until 12 MBaud (GSD-file is provided),
CANopen with baud rate until 1 MBaud (EDS file provided)

Structural shape and connections:

- euro card format (100x160), front panel and 32 pole connector (DIN 41612) for mounting into 3 HE 19 inch systems e.g. ELK-/ELR-systems – see pages 17 until 23)
- motor leads, power supply, connections for limit and home switches via 32 pole connector, or via screw / spring terminals in case of using ELK / ELR – panel mount / rack – systems.
- digital inputs and outputs via 25-pole D-Sub female connector
or optionally via additional 32 pole connector (DIN 41612)
– in case of using an ELR rack system and the SERS with additional 32 pole connector, the I/Os can be connected via spring terminals
- interface via 9-pole D-Sub connector or optionally via 32 pole connector (DIN 41612)
– when using ELR racks via spring terminals

Positioniersteuerung:

- **communication** by sending and receiving **ASCII characters** via the interface (for RS232 and RS485)
- simple and easy understandable syntax for all standard commands and parameters (see table on next page)
- programming of operational programmes similar to BASIC
- **3 different kinds of scaling** selectable for all position, speed and acceleration dates (**incremental** e.g. 5000 steps, **rotational** e.g. 1000 rpm and **linear** e.g. 20 mm/min)
- Parametrisierung von Getriebefaktoren und Vorschubkonstante (z.B. Spindelsteigung) für translatorische Werteangaben
- Velocities from 0,12 until 10000 rpm (stepping motor usable until approx. 3000 rpm, depending on motor and supply)
- acceleration from 2 until 15600 U/s² and linear, exponential or sinus acceleration characteristics
- **2 KByte E²Prom-memory** (depending on program up to **300 lines**, optionally **8 KByte** for up to 1200 lines) for storing an operational program in standalone mode, master-slave mode, parallel (BCD) mode
- backlash function for using e.g. gear boxes, chains, or spindles with backlash
- print mark control (automatical set or reset of outputs after reaching a certain position)
- travel distance after stop signal (after a stop command / signal the motor continues moving for a defined distance)
- arithmetical operations: +, -, * , /, AND, OR, EXCL-OR, NOT, NEG – usable with alle SERS parameters
1 accumulator for calculating and 12 free usable registers (R0 - R11)
- all SERS parameters can be programmed and changed anytime, also within an operational program
- Program jumps (GOTO) and subroutine calls (GOSUB)
- conditional jumps and commands (IF-commands) by query of inputs, markers, drives status and parameters, programmable with IF ... THEN ... ELSE structures
- wait function »WAIT...«, with user defined wait condition (e.g. wait for a signal at digital inputs)
- programmable delay function, with units in 10ms
- timer function (parallel to an operational program)
- counters (e.g. for realising program loops)
- manual driving functions (jog)
(without set target position, started via inputs or commands, with variable speed - can be changed during motor movement)
- extensive diagnostics – all errors and warnings can be inquired any time via the interface
- selection of language for the communication with the SERS e.g. error messages and parameter designations)
– German and English
- velocity profile mode – positioning with different speeds within one positioning job

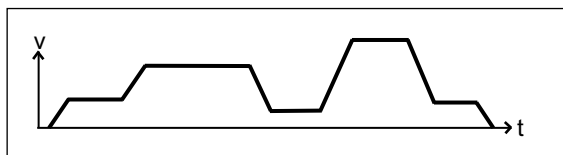

- Master-Slave-system programmable, with multiple axis (see illustration page 25), which can be synchronized to each other
 - easy realisation of the Master-Slave-system due to communication and synchronisation via RS232-interface
 - the Master-SERS may contain the complete operational program and it may control all SERS-slaves, or there will be programmed subroutines (parts of the whole program) into the slaves
 - the Master-SERS is able to read and change all parameters and use all functions of the SERS-slaves
- and many other functions (all together more than 100 different functions and parameters)

28 Position control – series SERS

Programming a SERS with RS232-interface via a PC or the SERS-Programmer 2

Software for programming a SERS with RS232 via a PC:

For SERS with RS232 interface a free programming software in DOS-version and Windows version (Win95 / 98 / NT / 2000 / XP) is provided via CD and can be downloaded from the internet.

Additionally to the manual (pdf-file on CD) an online help (windows help file) with explanations of most of the SERS-functions is included in the delivery of a SERS.

When opening the online help during running the programming software, the corresponding explanations will be displayed directly.

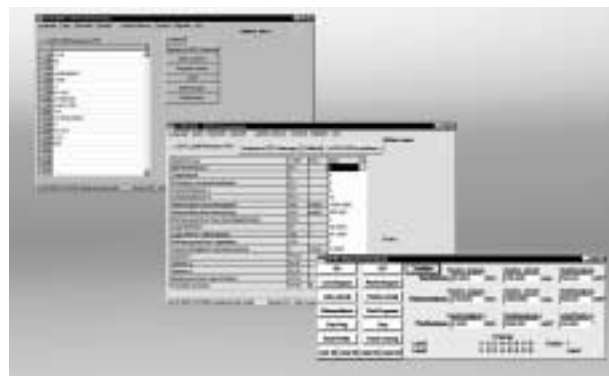

SERS programming-software (Win95 / 98 / ME / NT / 2000 / XP / VISTA) included in standard version

Typical standard commands in the serial operation mode:	
ON	switch on motor current
OFF	switch off motor current
V=1000	set motor velocity to 1000 (depending on adjusted scaling – e.g. rotational 1000 rpm)
W=100	set position command value to 100 – e.g. 100 mm in case of linear scaling absolute position in case of absolute positioning or distance in case of relative positioning mode
E	start positioning / execute positioning job – the drive starts positioning to the set position command value
S	Stop
POS?	request to the SERS, if the motor reached it's position – the SERS will return »POS = 0« oder »POS = 1«

Example operational program (e.g. standalone mode)	
1: L1	program label L1 (program label for jump commands)
2: WAIT I1=1	wait until input I1 is set
3: O1=0	output O1=0
4: W=55 E	position command value = 55 and start positioning (»E = execute«)
5: W=10	position = 10
6: IF I2=0 E	if input I2 is not set, then start positioning
7: O1=1	output O1=1
8: GOTO 1	jump to program label L1 (here at line 1)

Example Program BCD / parallel mode	
1: L1 ON RT	subprogram 1: Motor phase current (ON) and stop subprogram 1 (RT)
2: L2 OFF RT	subprogram 2: switch off motor current (OFF) and stop subprogram 2 (RT)
3: L3 O1=1 V=1000	subprogram 3: output O1=1, velocity V=1000
4: W=55 E O1=0 RT	Position = 55, Start Positionieren (E), after stop of positioning output O1=0 and stop subprogram 3
5: L4 O1=1 V=300	subprogram 4: output O1=1, velocity V=300
6: W=230 E O1=0 RT	Position = 230, Start positioning (E), after stop of positioning output O1=0 and stop subprogram 4
7: L5 O2=1 H O2=0 RT	subprogram 5: output O2=1, Start homing (H), after stop homing O2=0 and stop subprogram 5

SERS-Programmer 2:

- low priced programming device, in case no PC can be used
- easy to use control panel, e.g. for using in a produktion facility, for modifying parameters or program lines

Special features of the SERS-Programmer 2:

- the keypad with integrated 16x4 character display is suitable especially for dirty environments (frontside IP65 protection degree)
- colored marking of the threefold configuration of the keypad keys

Standard mode:

pre-defined standard menu with following possibilities:

- setup parameters in the SERS-control
- setup / modify operation programs in the SERS-control
- possibility of locking or releasing certain parameters and program lines via a password
- free definable text in the display for single value assignments, in an operational program
- start / stop manual drive functions (jog) and homing, via keys at the SERS-Programmer 2
- start / stop of SERS-operational programs
- start / stop of a Master-/Slave-system with one SERS as Master and further SERS as Slaves
- display of digital Inputs and Outputs (e.g. for verifying the SERS-I/Os during setup / installation of a machine)
- terminal function for communications with SERS-controls
- available as housed version (hand device), or for installing in 19" systems (e.g. STÖGRA ELK-racks), respectively for integration in any kind of control / operator panels

Extended programming mode:

- free programmable customer specific operator menus (ready menu examples exist), for realising simple menus with single level (see example below), or also menus with multiple levels
- free assignment of SERS-Programmer 2 keys to customer specific programmable functions
- operational program can be stored completely in the SERS-Programmer 2
- Master-Slave-system with SERS-Programmer as Master and all SERS drives as Slaves

Simple example for extended programming mode:

Via a SERS-Programmer 2 the machine operator shall modify just the travel distance, and he shall start and stop the operational program.

The menu, which can be accessed by the operator, shall be as simple as possible.

In the adjacent example, with key F1 the travel distance can be modified. With F3 the operational program (hidden in the background) can be started, and via the key »STOP« (unique key which is labelled with »stop«) the program respectively the motor movement can be stopped.

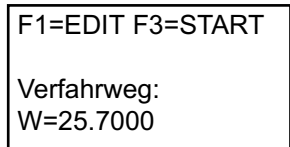

display of SERS-Programmer 2

SERS-Programmer 2 versions



SERS Programmer 2
housed hand programming device



SERS Programmer 2R
for integrating into front panels or 3-HE rack systems (ELK/ELR)

Dimensions

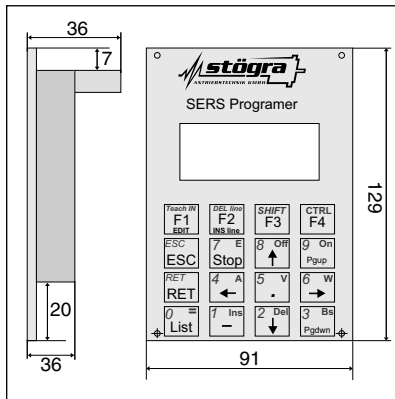

30 Position control – series SERS

Option Closed Loop Control

The SERS/WSERS is available optionally with **Closed Loop** control. The stepper motor must be a STÖGRA type with adjusted H500 encoder (motor option »C500« e.g. SM 87.2.18M6 C500). The SERS/WSERS must be ordered with option »E50/C« (e.g. WSERS 04.80 V01 E50/C).

A stepper motor system with Closed Loop control combines the advantages of stepper motors

- high response in case of short positioning movements
- no hunting at stand still
- no Gain Tuning necessary
- small load angle

with the advantage of Servo Motors (motor does not lose its synchronism – no more losing steps).

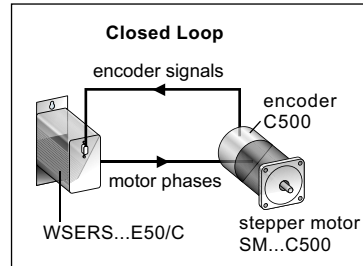

By using Closed Loop control the stepper motor can be operated always with its maximum torque.

The result is a high dynamical operation (with maximum motor acceleration).

When sizing a stepper motor system the usually planned torque safety can be reduced or maybe even skipped.

For many applications therefore a smaller motor can be selected.

Stepper Motor in open loop compared with Stepper Motor in Closed Loop Control

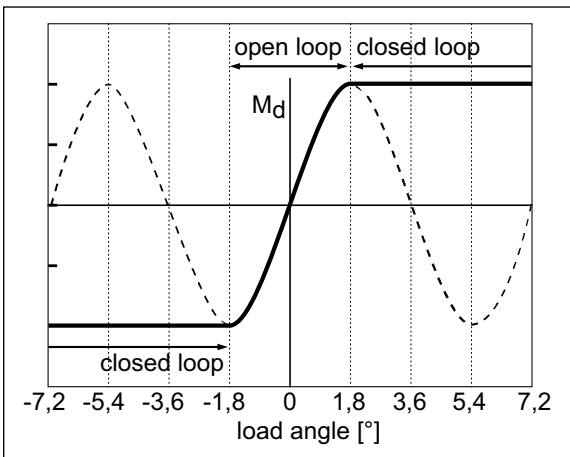

As long as the load angle is $<1,8^\circ$, the stepper motor will be operated in open loop mode.
If the load angle is $\geq 1,8^\circ$ (in open loop the motor now would lose its position) the stepper motor will be operated automatically in »closed loop mode«.

Stepper Motor in Closed Loop Control compared with a Servomotor

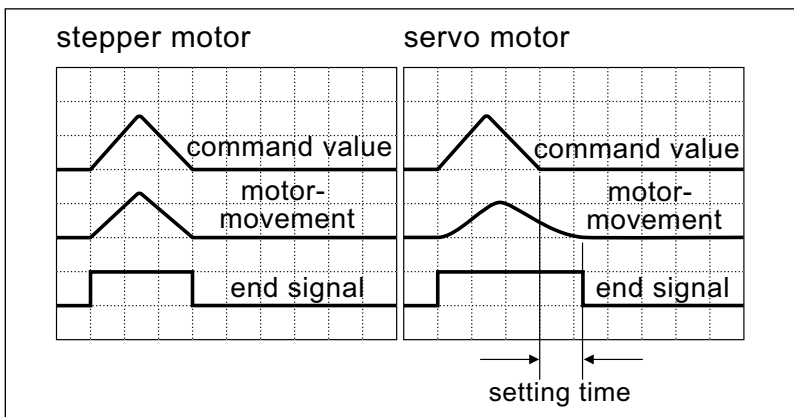

The stepper motor follows its position command values immediately (left picture).

But a SERVO motor can only start and stop with a delay / settling time, due to its system, where the position needs to be monitored continuously (right picture).

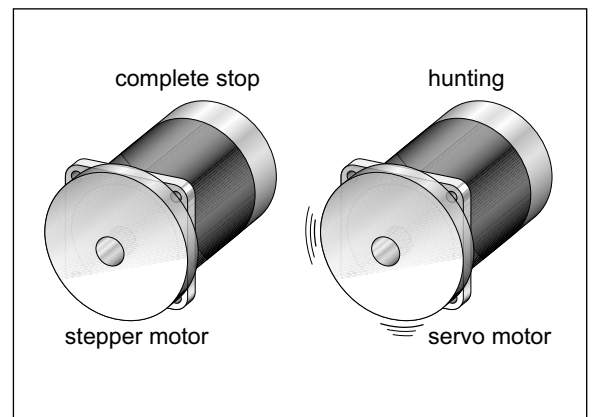

At motor stand still the stepper motor completely stands still (left picture).

But a SERVO motor is slightly moving forward and backward around its standstill position (what is called hunting – right picture).

Option **E50 encoder input**

The SERS-stepping motor control is available optionally with encoder input (SERS...V04 E50).

2-channel encoders (A, B and \bar{A} , \bar{B}) with any resolution (e.g. 2 x 50 impulses/rev. or 2 x 1000 impulses/rev.) can be connected.

The SERS... V04 E50 includes 2 different encoder signal inputs:

- **Encoder input 1** (9-pole D-Sub female connector at the SERS-front panel):

The signals are evaluated 4 times (with recognition of direction). Out of the signals of e.g. a 1000 pulse encoder there are created 4000 increments. The signals pass a RS422-input circuit and analogue and digital filters. This guarantees a very high level of noise immunity. The encoder input can be used for the control of step angle (with complete correction of lost steps after a mechanical overload at the motor – correction of actual position or driving to the target position with lower velocity) or for connecting a hand wheel or another motor (with encoder output) for realizing an electrical gearing function.

- **Encoder input 2** (inputs I3 and I4 of the digital inputs):

Signals A and B are evaluated 4-times (no evaluation of the inverted signals). This encoder input can be used for realizing a hand wheel function respective an electrical gearing function.

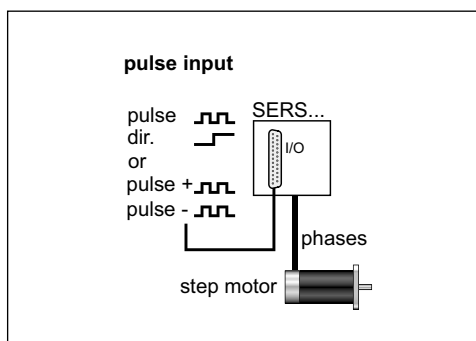
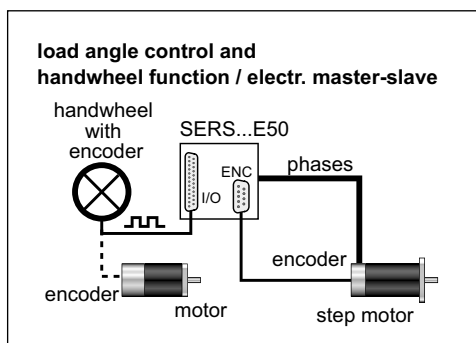
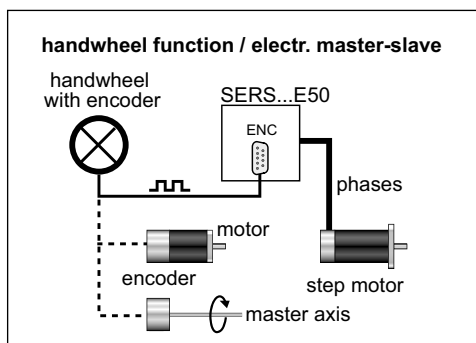
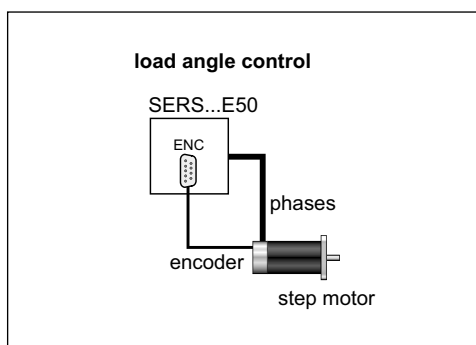

Control of load angle

The signals of an encoder mounted at the stepping motor are connected to the SERS. The SERS compares the position created by the encoder signals with the internal actual position command value.

If the difference between both values is too big (difference value adjustable), then an error message (or warning – selectable) will be created and the motor will immediately decelerate until stop (if error is preselected).

Correction of position (closed loop)

After a load angle error the lost steps can be corrected (driving with homing velocity to the position command value / target position) or the position command value is set to the real actual motor position (given by the encoder).

Hand wheel function / electrical gearing (master-slave) function

The signals of a hand wheel or the signals of an encoder mounted on any other shaft are connected to the SERS. The SERS (respective the motor controlled by the SERS) follows these encoder signals. The relation between the number of encoder signals (movement of the handwheel / other motor / shaft) and the movement of the stepping motor (controlled by the SERS) can be adjusted.

Pulse input

Encoder input 1 and encoder input 2 also may be used as pulse inputs. There are two possibilities:

1. Signal pulse and signal direction
2. Signal pulse in positive direction and signal pulse in negative direction

The movement (distance) related to one pulse can be selected via a parameter in the SERS. In case of a pulse chain with high frequency without ramp the pulses will be buffered in the SERS and the SERS creates the ramp with the preselected parameters acceleration »a« and maximum velocity »v«.

32 Position control – series SERS

SERS with Profibus-DP/V0 interface

Output	control word (4 byte)	opcode (2 byte)	operand (4 byte)	acceleration (4 byte)	velocity (4 byte)	position / travel (4 byte)
Input	status word (2 byte)	result of parameter value request (4 byte)	actual position (4 byte)	digital inputs (2 byte)		
Diagnostics	error (2 byte)	warning (2 byte)	error no. (1 byte – code for more than 100 detailed error messages)			

Control Word

the control word triggers below actions after being changed. »STOP« will be evaluated always.

Bit 0: SLOW_NEGATIVE (jog 1 = active, 0 = Stop)

Bit 2: FAST_NEGATIVE (jog 1 = active, 0 = Stop)

Bit 4: HOMING (1 = active, 0 = Stop)

Bit 6: STOP (1 = stop active, 0 = moving enabled)

Bit 8: START_POSITIONING (edge 0 to 1 = start)

Bit 13: RESET_ERROR (edge 0 to 1: P11=0)

Bit 15: EXECUTE_OPCODE (edge 0 to 1 = »opcode« will be executed)

Bit 16: START_POSITIONING_TOGGLE (at change of this bit will start the drive)

Bit 17: ABSOLUTE (positioning mode – absolute or relative)

Bit 19: POLYNOM_TERM 1 = (termination of polynom / last polynom section)

Bit 20: PARAMETER_ACCEPT (the parameter »acceleration«, »velocity« and »position command value« in bytes 11 until 22 will be used in case of a start positioning via the control word (bit 8 or bit 16).

Bit 21 bis 31: reserved

Bit 1: SLOW_POSITIVE (jog 1 = active, 0 = Stop)

Bit 3: FAST_POSITIVE (jog 1 = active, 0 = Stop)

Bit 5: PHASE_CURRENT_ON (1 = ON, 0 = OFF)

Bit 7: START_PROGRAMM (1 = Start)

Bit 9 bis Bit 12: OUTPUT 1 to OUTPUT 4 (digital outputs)

Bit 14: RESET_WARNING (edge 0 to 1 - P12=0)

Bit 18: POLYNOM 1 = (activates the polynom positioning mode)

Operation Code and Operand

Via the Operation Code bytes and the Operand bytes any SERS parameters (e.g. motor phase current) can be set.

»Operation Code« = SERS – parameter number and »Operand« = parameter value

For setting up a parameter only the correct Operation Code and value must be written into the corresponding output bytes and Bit 15 in the control word must be set.

Even complete operational programs may be saved into the SERS by using the Operation Codes and Operands.

Acceleration, Velocity and Position

Via the bytes acceleration, velocity and position a positioning job may be initialised directly. Via Bit 8 or Bit 15 in the Control Word the positioning job can be started. Bit 10 in the Status Word indicates if the target position is reached.

Status Word

In the status word the complete SERS status is shown and may be read anytime from the Profibus-Master unit.

Bit 0: READY_TO_SWITCH_ON is always 1

Bit 2: OPERATION_ENABLED (phase current ON)

Bit 4: SETPOINT_ACKNOWLEDGE (next Polynom section is expected)

Bit 7: WARNING P12 <> 0 (a warning is active)

Bit 9: REMOTE P0=0 (no running program active)

Bit 11: INTERNAL_LIMIT_ACTIVE (limit position overflow)

Bit 13: FOLLOWING_ERROR (error load angle – only for SERS with option E50)

Bit 14: ACCELERATING_PHASE (motor is accelerating)

Bit 1: SWITCHED_ON P134 <> 0 (phase current is ON)

Bit 3: FAULT P11 <> 0 (an error is active)

Bit 5 und Bit 6: not used

Bit 8: HANDSHAKE SERS (finished last opcode execution)

Bit 10: TARGET_REACHED (motor not running / position reached)

Bit 12: HOMING_ATTAINED (after successful homing procedure)

Bit 15: CONSTANT_PHASE (motor runs with constant velocity)

Result of parameter value request

For requesting the actual value of any parameter, via the Operation Code a parameter request may be started.

The actual value of the requested parameter will be written into the bytes »Result of parameter value request«.

Actual Position

The SERS writes continuously its actual position into the bytes »actual position« and can be read out at any time.

Diagnostics

In the diagnostics section all warnings and errors are indicated detailed.

E.g. during setting up new projects this gives very detailed feedback to the software engineer programming the SERS. But also at the customers application, via the diagnostics any kind of error (e.g. short circuit at motor / amplifier, warning overtemperature amplifier, STOP switch active and therefore no movement possible, invalid value set because to big or to small, and many more detailed messages) may be monitored. Over 100 different detailed error and warning messages are indicated via an error code.

GSD-file (Profibus configuration file)

A GSD-file is provided for an easy configuration of the SERS unit at a Profibus-DP master.

Also a complete manual (pdf-format) for the SERS with Profibus-DP drives is provided.

SERS with Profibus-DP/V1 interface and PROFIdrive protocol V3.1:

The SERS with PROFIdrive interface follows the specifications of the PROFIdrive profile drive technology Version 3.1.

Profibus-DP/V1 (sometimes also called Profibus-DP/V2 in case of PROFIdrive) is implemented in the SERS.

The SERS drive is an application class 4 drive, where the PROFIdrive master calculates and cyclically transmits speed setpoint values and the SERS returns actual position values and status word (closed position loop control realized via the Profibus).

A clock synchronism ensures high timing precision and exact synchronising of all connected drive axis.

This enables position interpolation with high precision and speed of multiple drive axis via the Profibus.

All SERS units with PROFIdrive also support the Profibus-DP/V0 mode (described at page 28).

Specifications of the SERS with PROFIdrive

- operation with any PROFIdrive-Master (e.g. Siemens Simotion control)
- implemented operating mode: speed control mode (application class 4)
- supported cycle times: 2ms and 4ms (for other cycle times please contact STÖGRA technical support)
- status word and control word according to PROFIdrive profile 3.1

A Profibus (PROFIdrive) configuration file (GSD-file) is provided.

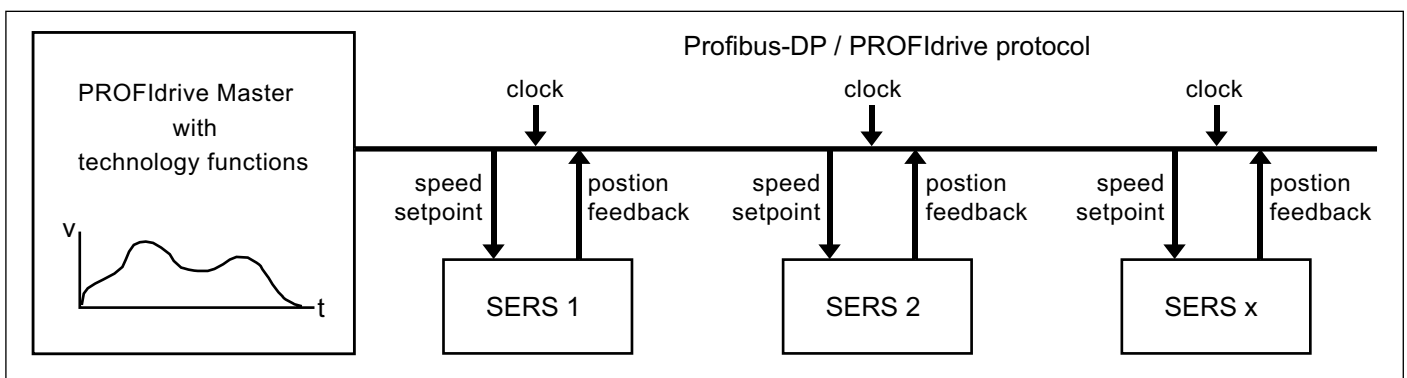

A motion profile for multiple axis (e.g. an interpolation in a 3D system with X-Y-Z axis) is given to a PROFIdrive master.

A closed position control loop via the Profibus is realised by cyclically transmitting speed setpoint values to the drives and receiving actual position values from the drives (controlled by a clock synchronism with time stamp).

For achieving the wanted position at the different axis the position feedback values are used for calculating the speed setpoint values for the next cycle.

This dynamical interpolation system also enables changing the profile at any time online, respectively generating the profile continuously (when starting the first movement, the following movements – positions and speed – are calculated online depending on any actual new events).

SERS with CANopen interface:

SERS units with CANopen interface include following specifications:

- standard parameter of the »CANopen Device Profile for Drives and Motion Control« of Index 0x6000 are according to »CiA confirming to Draft Standard Proposal **DSP-402**«
- general (e.g. communication) parameters with index numbers until 0x1000 are implemented according to »CiA Draft Standard 301« (Application Layer and Communication Profile) from »CAN in Automation e. V.«
- 11 Bit identifier used
- implemented positioning modes ("modes_of_operation" (6060)): 1 »Profile Position Mode« and 6 »Homing Mode«
- galvanically isolated CANopen interface with selectable Baudrates up to 1Mbaud
- all functions of the standard SERS with RS232 interface are implemented (see description page 22 to 27)
- EDS-file provided including reference to all manufacturer specific SERS parameter
- manual (pdf-format) provided

34 Position control – series SERS

SERS with separated 24VDC logic supply – option »U«:

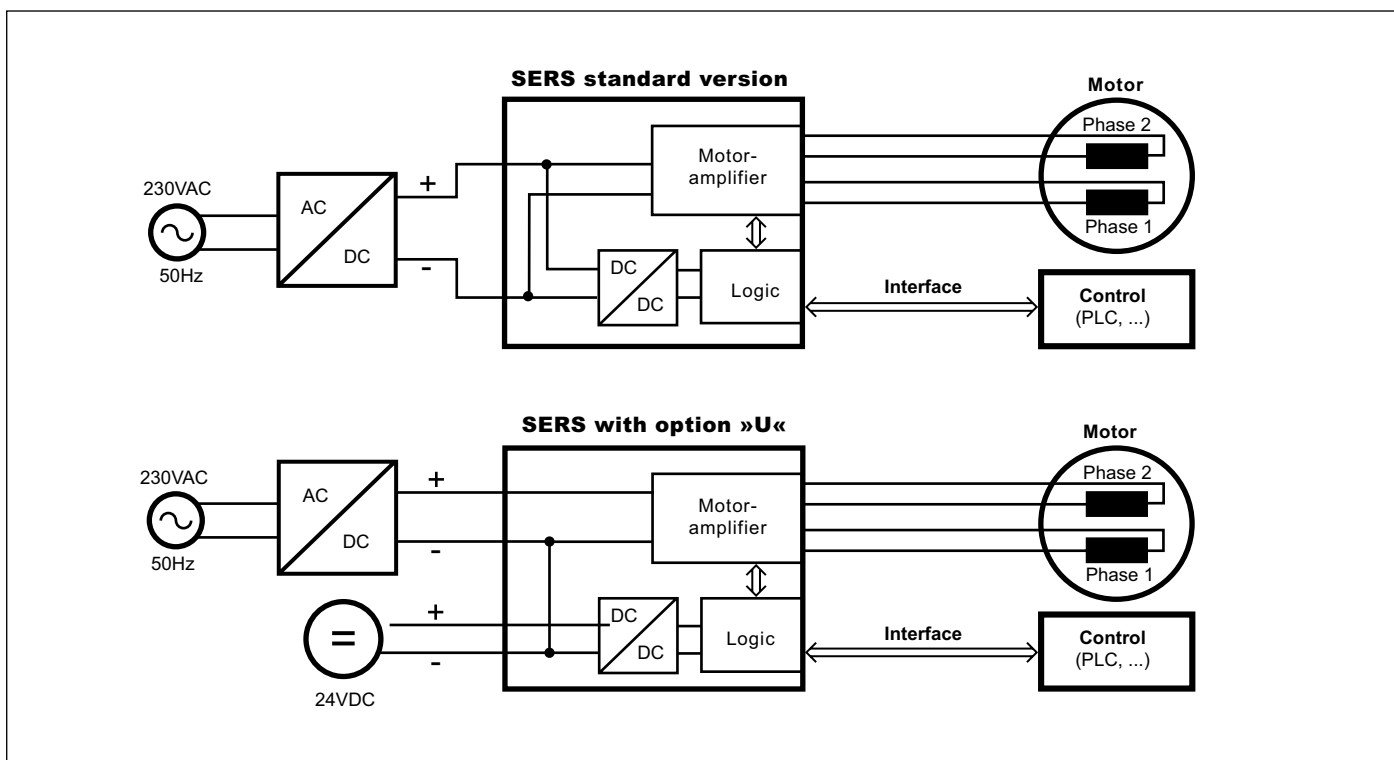

SERS standard version:

The SERS unit is supplied by an external common voltage supply (depending on SERS-version from 20 - 240VDC, respectively 230VAC in case of WSERS xx.230AC versions). This common voltage supplies the SERS-Logic as well as the SERS-power stage.

The internally needed low voltage for the SERS-Logic is generated by an internal DC/DC-stage (internal power supply).

In case of switching off the common power supply, the motor power is switched off as well as the logic (position control unit in the SERS) and the interface of the SERS.

SERS with option »U«:

SERS-controls with Option »U« (SERS ... U) need two separate voltage supplies (option »U« is recommended for controls with Profibus- or CANopen-interface, and in certain applications for SERS-controls with encoder interface):

- the motor (SERS power stage) is supplied by the main voltage (depending on SERS/WSERS version 20 - 240VDC / 230VAC)
- the Logic (position control and interface) is supplied by a separate 24VDC voltage

In case of needing to switch off the motor power (e.g. for safety reasons) the logic still can be supplied by 24VDC and therefore it still can be active (in operation).

This version may be used e.g. for keeping alive the interface (e.g. Profibus or CANopen) and its communication.

In case the switch off of the voltage supply is delayed (e.g. via a contactor with delay function) after a STOP-signal at the STOP input of the SERS, then this is a simple way of realising a »safe torque off« function.

The separate logic supply is externally via the input »service switch external« by +24VDC. The 0V (Minus) of the 24V is connected to the common GND of the SERS respective GND (24V) at ELK-racks and GND (VCC) at ELR-racks (ELK-racks must be ordered with the Option »V«).

WSERS units include separate input connections for the separate 24V supply.

As standard SERS / WSERS units do not include option »U«, this option (separate 24V logic supply) must be ordered separately (see ordering key at page 36 and 39).

SERS block diagram

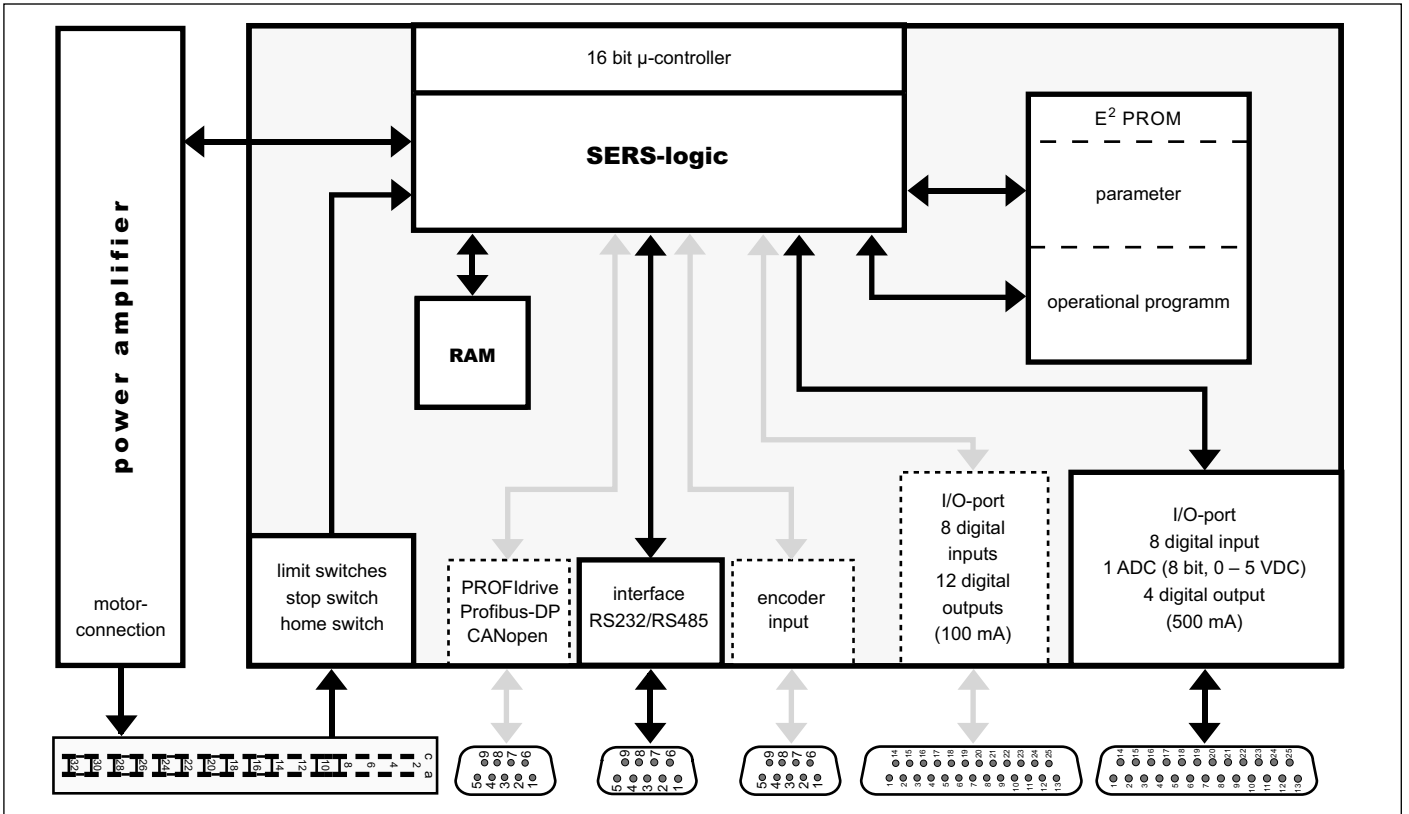

Voltage supply:

Nominal voltage	24VDC	60VDC ¹⁾	85VDC	120VDC	240VDC
Voltage supply range	20 – 40VDC	45 – 70VDC	45 – 85VDC	60 – 120VDC	120 – 240VDC

¹⁾ 60VDC versions are available only for 1A, 2A and 3A SERS boards
 Also 1A, 2A and 3A SERS boards are available only with 24VDC or 60VDC



SERS 02.60 V04
 phase current: 0 to 2,8 A/Ph
 voltage supply: 60VDC
 – optionally SERS xx.yy V04
 with xx = 01, 02, 03 or 04
 (max. 1,4, 2,8, 4,2 or 5,6A/Ph)
 and yy = 24 or 60VDC available

SERS 06.85 V04
 phase current: 0 to 8,4 A/Ph
 voltage supply: 85VDC
 optionally SERS 06.24 V04
 and SERS 06.120 V04
 with 24VDC / 120VDC

SERS 12.120 V04
 phase current: 0 to 14,5 A/Ph
 voltage supply: 120VDC
 optionally SERS 12.85 V04
 and SERS 12.240 V04
 with 85VDC respective 240VDC

ELK 3.500.85/24.2
 SERC-controls are available also in mains ready panel mount and 19 inch systems in different sizes (see ELK-/ELR-systems pages 18 to 21).
 Photo above: 2-axis-SERCOS panel mountage rack with 500VA power supply and internal 85VDC voltage supply.

36 Position control – series SERS

Dimensions

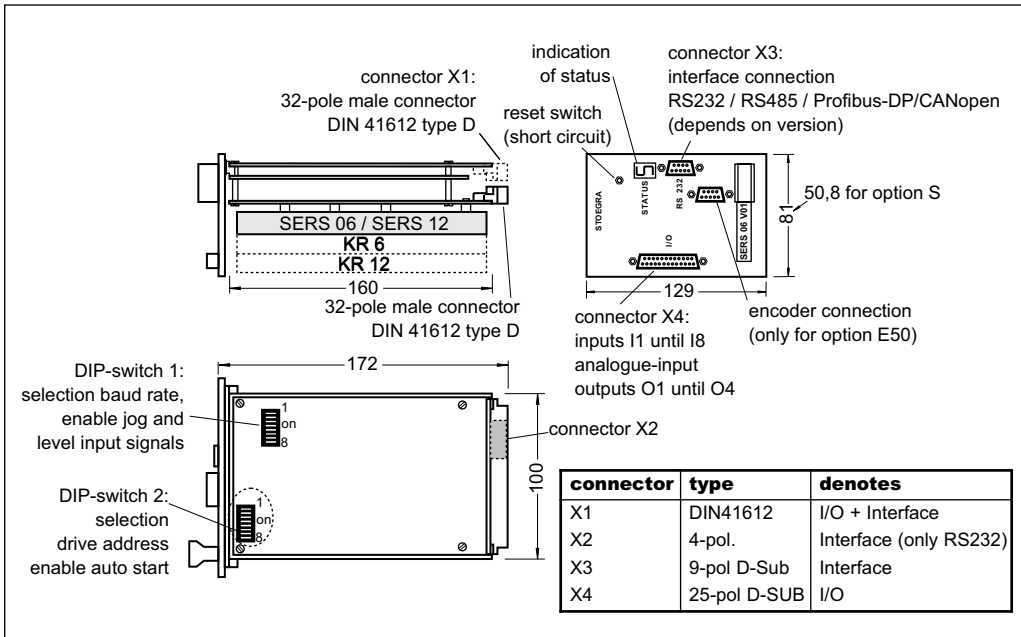

Option H:

SERS for mounting into board holder KH-SE_01 (see page 11) e.g. SERS 06.24 V04 H (board holder KH-SE_01 has to be ordered separately)



For panel mount and 19 inch systems with power supply for SERS controls → see ELK/ELR page 17

Connector options

option	X1	X2	X3	X4	description
R1	X		X		for ELR-racks – I/Os + interface via connector X1+ interface via 9-pol. D-Sub at front side
R2	X				for ELR-racks – I/Os + interface via connector X1
R3	X				for ELR-racks – I/Os + Interface via connector X1– without front panel
R4		X		X	for ELK-racks with option »I« or »I2« or »P« – interface at rear side via X2
R5		X	X	X	for ELK-racks with option »I« or »I2« or »P« – interface at front side and rear side
no indication			X	X	standard version

Ordering key (e.g. SERS 12.120 V04 or SERS 02.24 V04 E50 S or SERS 06.85 V04 R2 K6)

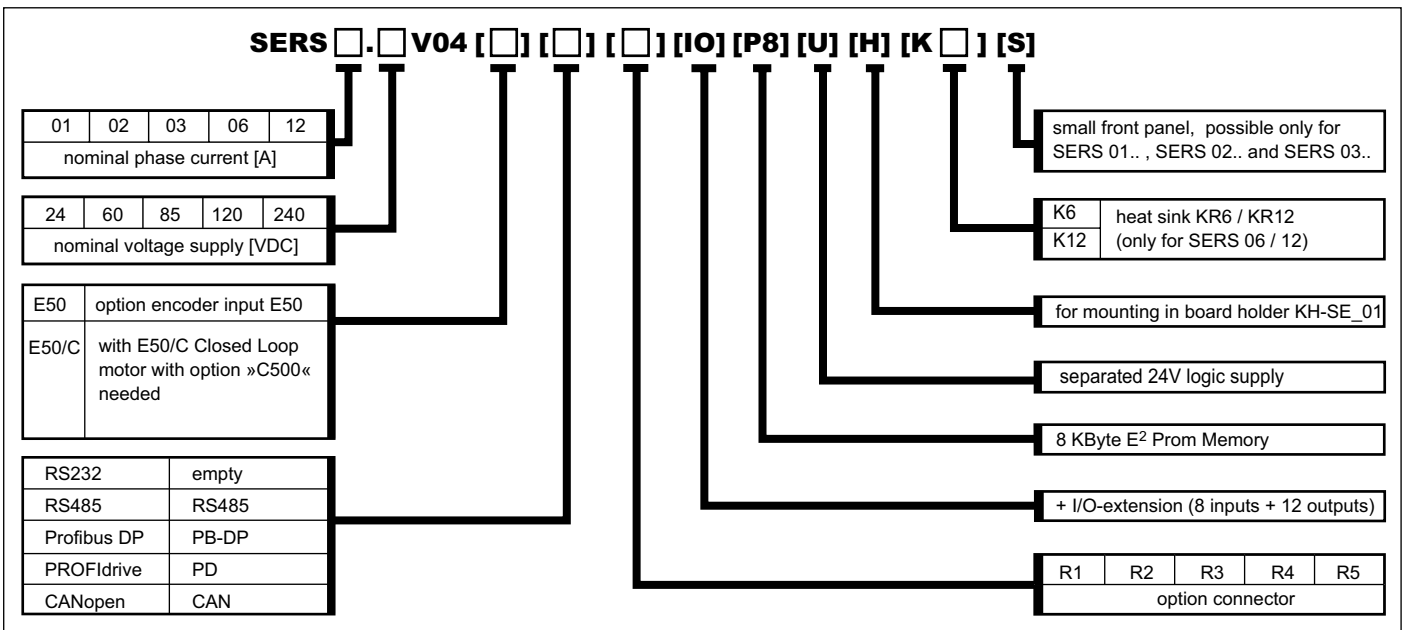

Fields in square brackets [] are for options. This field needs to be indicated, if the option is required.

1A, 2A and 3A SERS boards only available with 24VDC or 60VDC (also 60VDC only available for 1A, 2A and 3A SERS boards)

The stepping motor position control series WSERS controls 2-phases stepping motors.

A unit consists of a power amplifier, a micro-stepping power amplifier control and the position control. The communication with the position control is via an interface RS232C/V24, RS485, Profibus-DP, PROFIdrive or CANopen.

The WSERS guarantees an optimal, free of vibrations true running due to its microstepping operation with 12800 steps/revolution and the possibility to select different phase current characteristics to match the characteristics of the used stepping motor type.

The rough step by step operation of conventional stepping motor drives at low speed ranges has been improved extremely by the WSERS to a very smooth running (comparable with servo motors).

In standard version the WSERS can be operated in four different modes (see pages 24/25 – identical to series SERS).

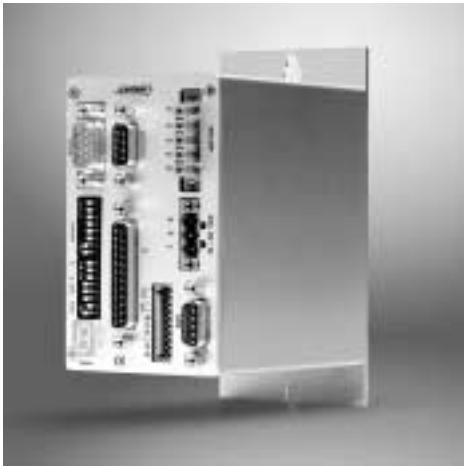

WSERS 04.80 V01 E50 PB-DP /W

phase current 0 to 4,2A/phase
voltage supply 20 to 80VDC
also available as WSERS 08.80 ...
with 0 to 8,4A/phase



WSERS 08.80 V01

phase current 0 to 8,4A/phase
voltage supply 20 to 80VDC
also available as WSERS 04.80 ...
with 0 to 4,2A/phase



WSERS 06.230AC V01 E50 PB-DP /W

phase current 0 to 6,0A/phase
voltage supply 230VAC/50-60Hz
also available as WSERS 04.230AC ...
with 0 to 4,2A/phase

Functions of the WSERS:

The functions of the WSERS are identical to the series SERS (see descriptions on pages 26 to 31):

Inputs / Outputs (for WSERS xx.115AC and WSERS xx.230AC the analogue input is an option which must be ordered extra), optional load angle control E50, interfaces (RS232, RS485, Profibus-DP, PROFdrive, CANopen), position control, option »U« (separate logic supply), programming (via software and SERS Programmer).

As the series SERS, the power amplifier stage of the WSERS includes microstepping with 12800 steps/revolution (will be switched dynamically at higher speed).

Versions phase current and voltage supply:

type	phase current	voltage supply	internal motor operating voltage
WSERS 04.80...	0 – 4,2A/phase	20 – 80 VDC	20 – 80 VDC
WSERS 08.80...	0 – 8,4A/phase	20 – 80 VDC	20 – 80 VDC
WSERS 04.115AC...	0 – 4,2A/phase	115VAC/50-60Hz	162VDC
WSERS 06.115AC...	0 – 6,0A/phase	115VAC/50-60Hz	162VDC
WSERS 04.230AC...	0 – 4,2A/phase	230VAC/50-60Hz	325VDC
WSERS 06.230AC...	0 – 6,0A/phase	230VAC/50-60Hz	325VDC

The versions WSERS xx.115AC and WSERS xx.230AC are for direct connection to the mains 115VAC/60Hz (e.g. USA) respectively mains 230VAC/50Hz (e.g. Germany) – see also description and diagram for series WSE ...230VAC at page 10.

The AC-voltage is converted into a DC-voltage within the WSERS, resulting in a motor operating voltage of 162VDC (at 115VAC) respectively 325VDC (at 230VAC). The WSERS xx.115AC and WSERS xx.230AC may only be operated together with motors with sufficient and special insulation (e.g. from STÖGRA all motors of series SM 88, and series SM 87 and SM 107 from production date 07.2006). The motors must be suitable for being operated with 325VDC (insulation test voltage 2000VAC 1s according to VDE530-1).

Versions for DIN rail and panel mounting:

The WSERS includes a closed metallic compact housing and is available in two different mounting versions:

- version for DIN rail mounting via a rear side rail mounting clip
- version for panel mounting via a rear side panel mounting bracket

38 WSERS – connections

WSERS 04.80 and WSERS 08.80

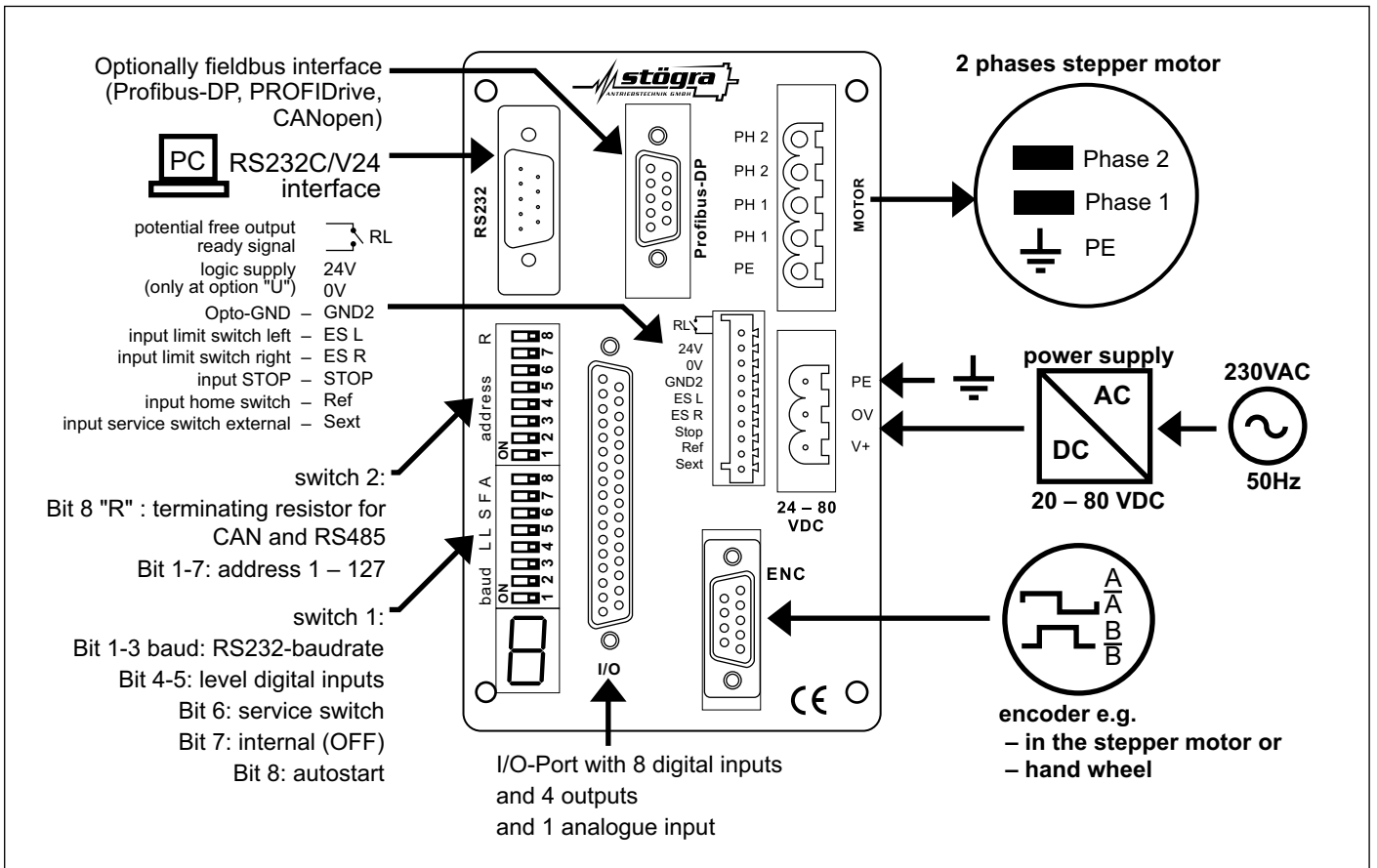

WSERS 04.230AC and WSERS 06.230AC

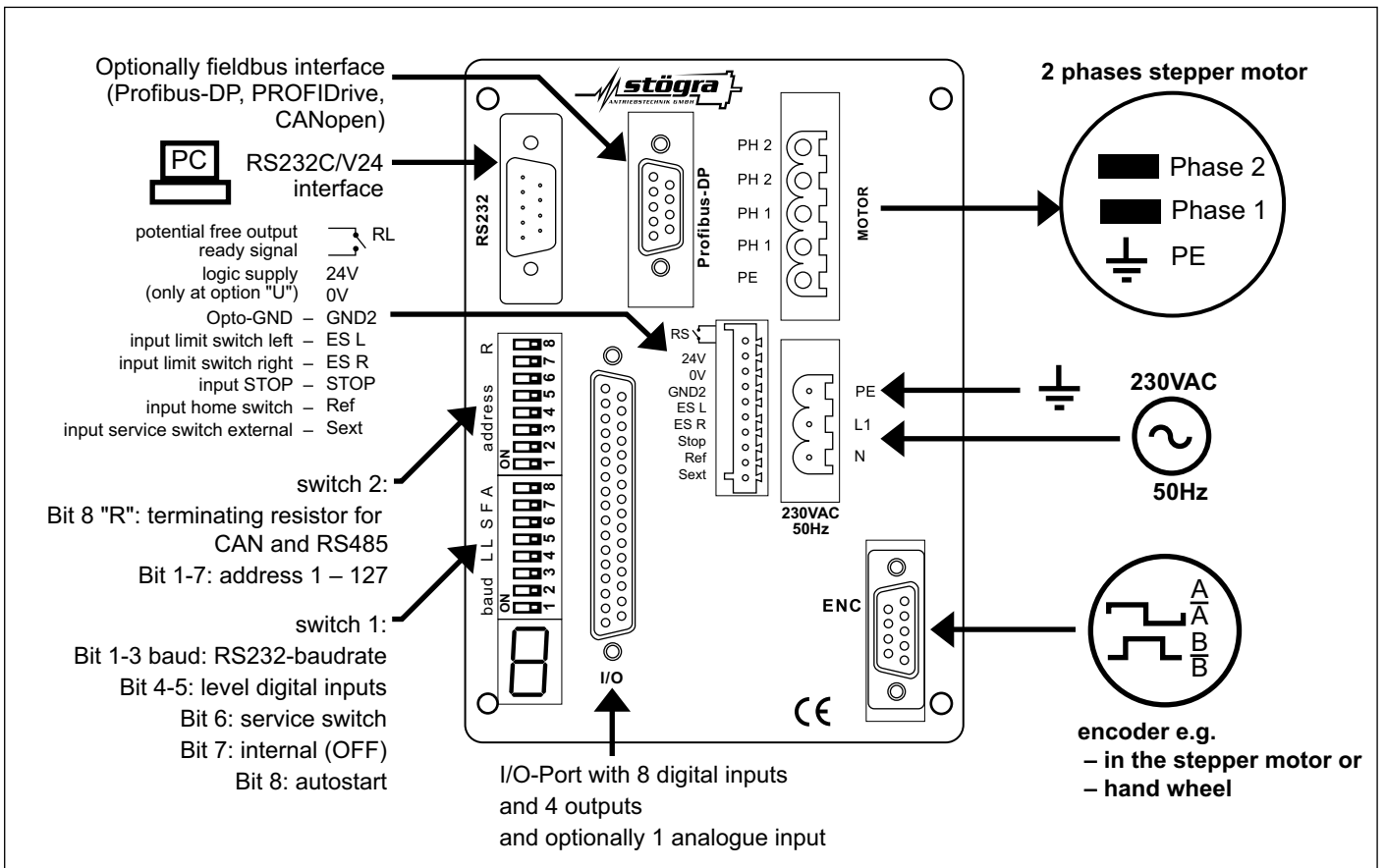

WSERS – dimensions, ordering key, specifications, equipment 39

dimensions

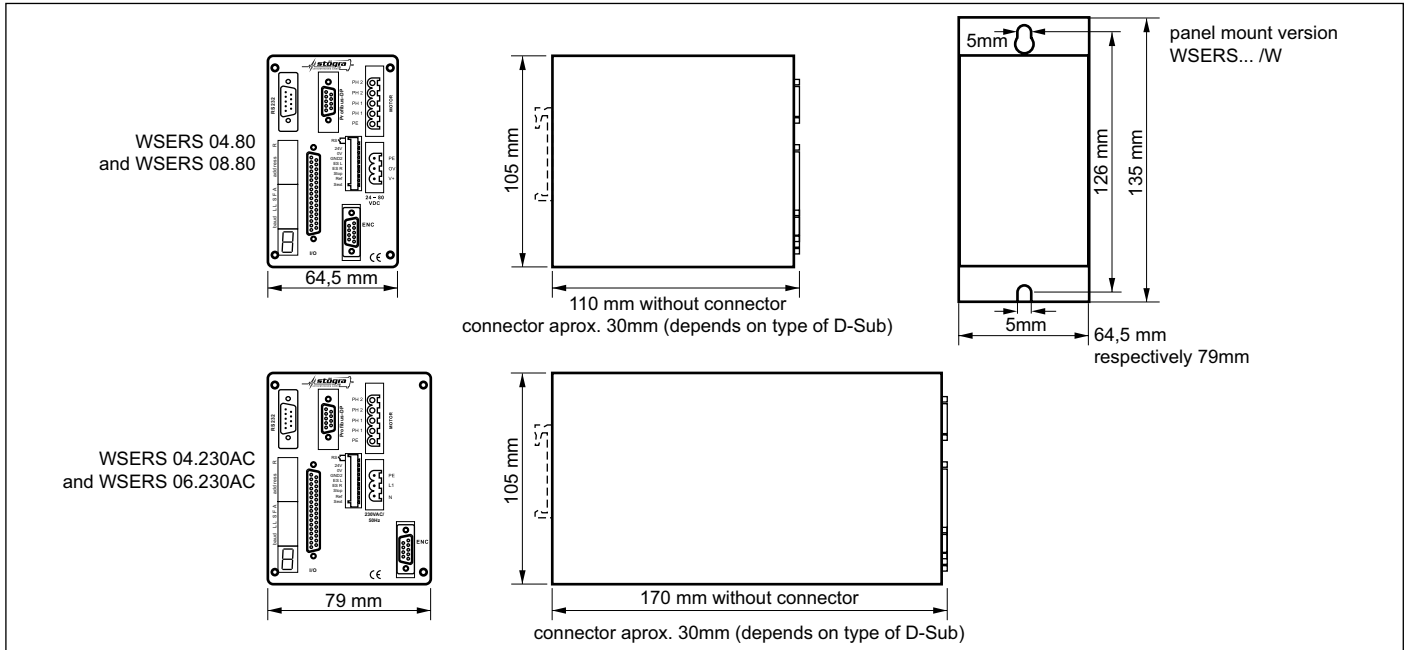

ordering key (e.g. WSERS 04.80 V01, WSERS 06.230AC V01 E50 PB-DP U, or WSERS 04.230AC V01 PD W)

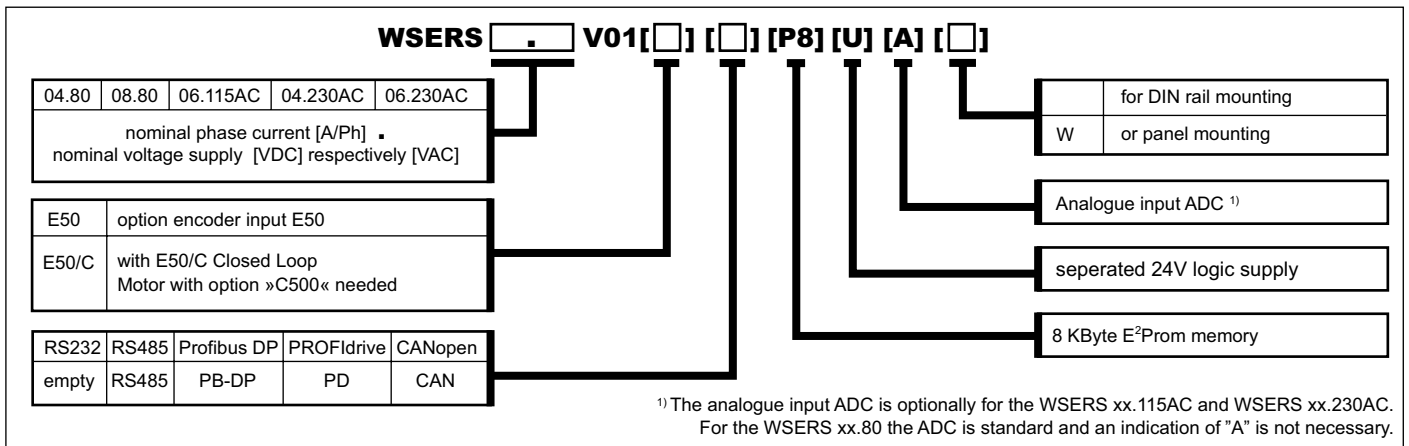

specifications WSERS

protection of device	<ul style="list-style-type: none"> protection class SERS IP00 (ELK: IP20), and WSERS IP20 protection against short circuit (motor phases), over temperature (SERS / WSERS) and under voltage 			
weight	SERS 01 / 02 / 03	SERS 06 / 12	WSERS xx.80	WSERS xx.230AC
	0,30 kg	0,60 kg	0,65 kg	1,05 kg
ambient conditions	<ul style="list-style-type: none"> ambient temperature: 0°C to 50°C forced draft: for SERS necessary from 12A adjusted phase current, for WSERS 06.230AC from 6A 			
noise immunity	if correct installed according to EN 50082-2			
noise radiation	if correct installed and shielded lines according to EN 55011 Klasse B			
RoHs conformdirective to 2002/95/EC				

equipment for SERS position controls



Screw terminal block for DIN rail mounting with 25-pole D-Sub-connector for easy connection of SERS / WSERS input-/output signals via screw terminals
Ordering key: **KBDS25**

Cabel (2m) with 25-pole D-Sub connector for connecting the I/Os of a SERS / WSERS with a screw terminal block KBDS25.
Ordering key: **LDS25**



Cabel (2m) with 9-pole D-Sub connector and 1:1 wiring for the connection of the RS232-interface of a SERS / WSERS to a control (e.g. PC) with RS232-interface.
Ordering key: **LDS9**



STÖGRA ANTRIEBSTECHNIK GMBH

Machtlfinger Strasse 24
 D-81379 München

Tel ++49-89-15 90 40 00
 Fax ++49-89-15 90 40 09

E-Mail info@stoegra.de
 Internet <http://www.stoegra.de>

www.stoegra.de



presented by:

