

24 Position control – series SERS

The stepping motor position control series SERS controls 2-phases stepping motors. A unit consists of a power amplifier, a microstepping power amplifier control and the position control. The communication with the position control is via an interface RS232C/V24, RS485, Profibus-DP, PROFIdrive, CANopen (DSP 402).

The SERS guarantees an optimal, free of vibrations true running due to its microstepping operation with 12800 steps/revolution and the possibility to select different phase current characteristics to match the characteristics of the used stepping motor type. The rough step by step operation of conventional stepping motor drives at low speed ranges has been improved extremely by the SERS to a very smooth running (comparable with servo motors). In standard version the SERS can be operated in four different modes:

Serial operation

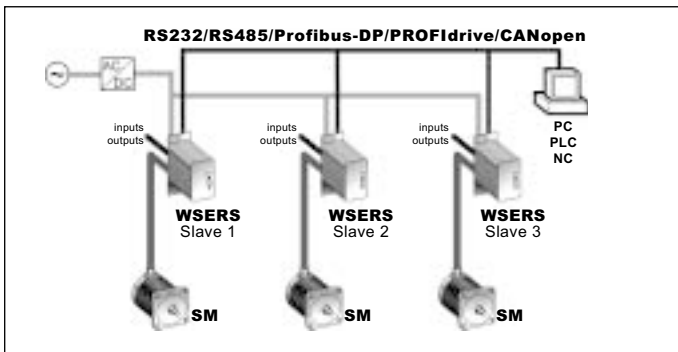

Operation with PC/PLC/NC as higher order control (master) and communication via a fieldbus / serial interface with SERS-slaves

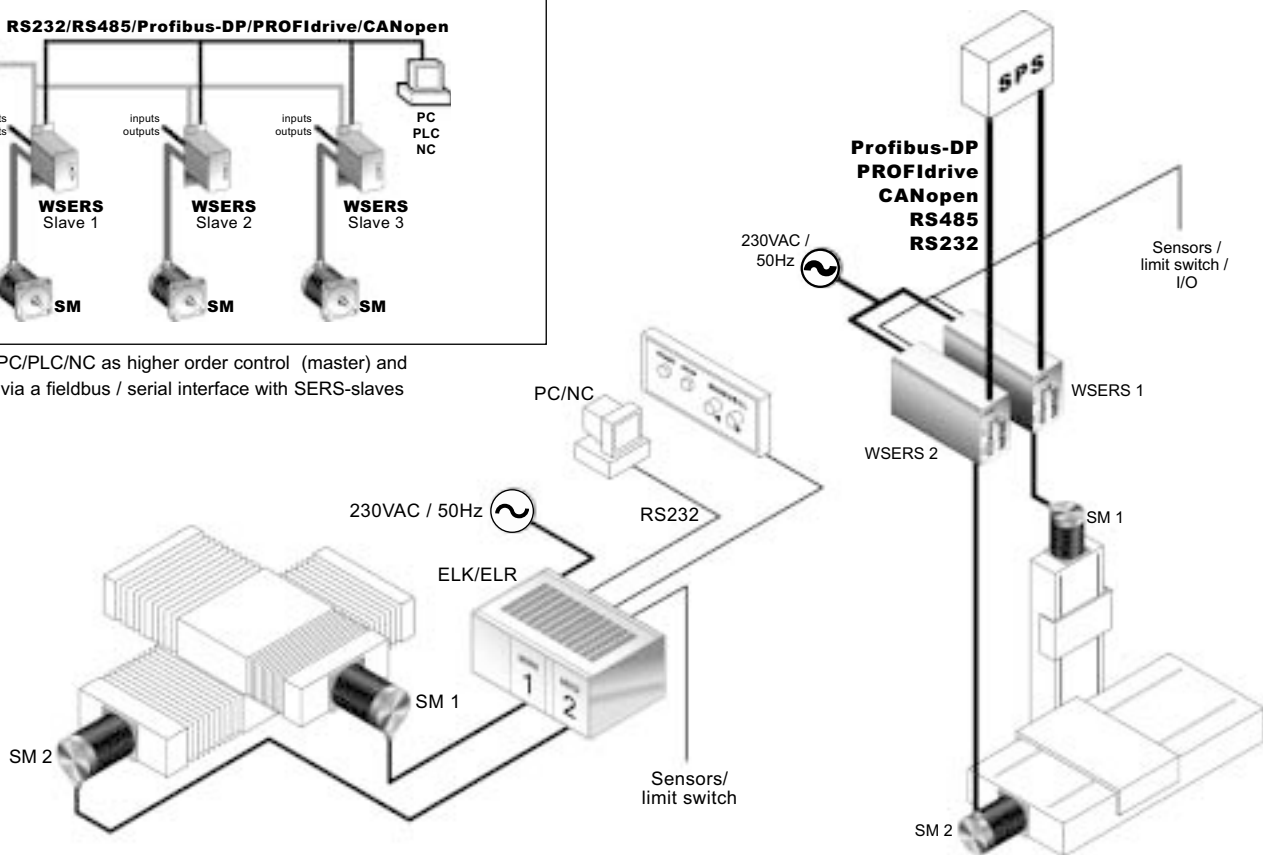

Standalone operation

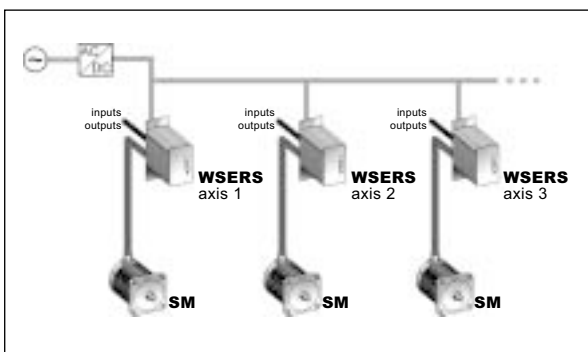

Operation with SERS-slaves as independent working axis, with stored operational programs, controlled by events at the digital inputs – e.g. manual start switch, limit switch, light barriers.

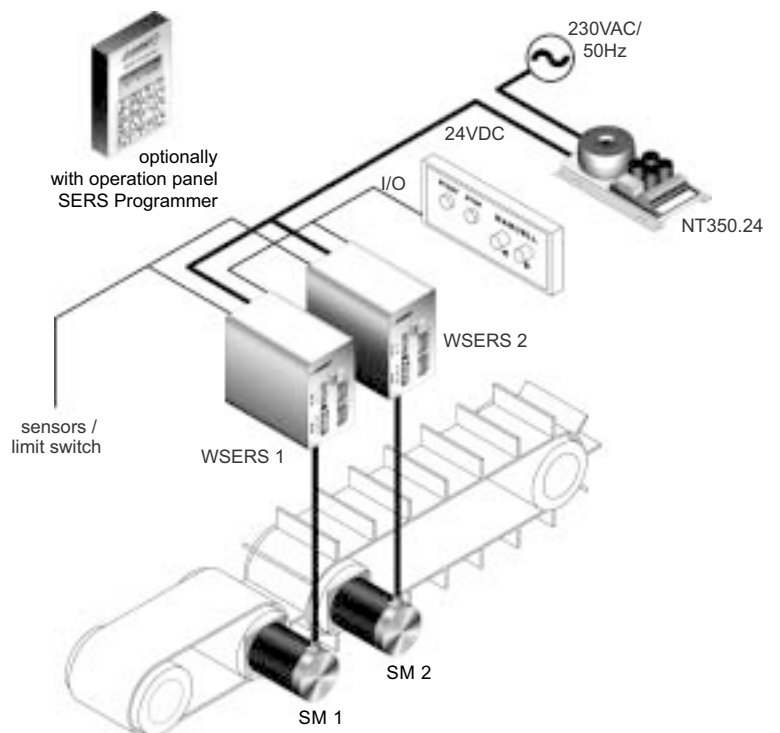

Parallel (BCD) operation

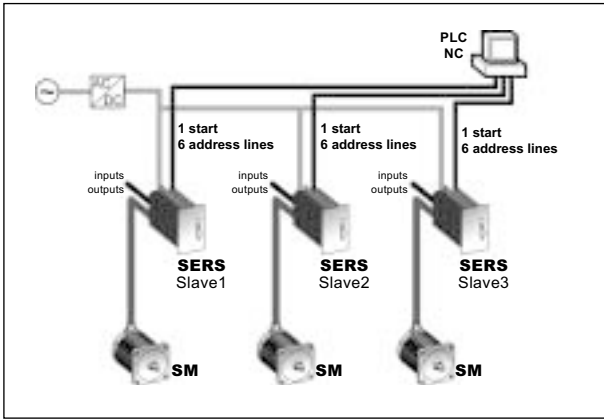

Operation with a PLC/NC or simple switches as higher order control, which call and start different operational programs in the SERS via the digital-parallel inputs (binary mode). Up to 64 different operational programs per SERS can be called.

Master operation

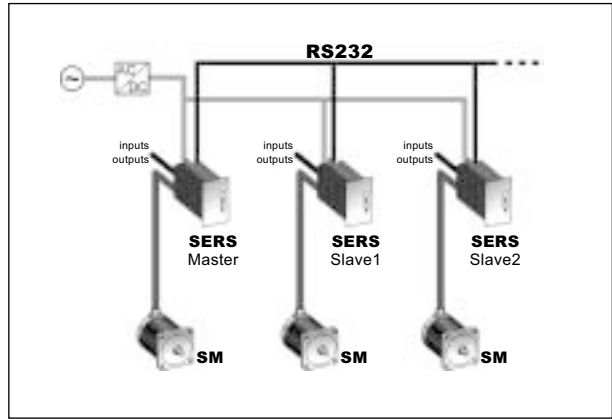

Operation with a SERS as higher order intelligent control (master), which controls other SERS-slaves via the serial interface.

No other (higher ranking) control necessary!

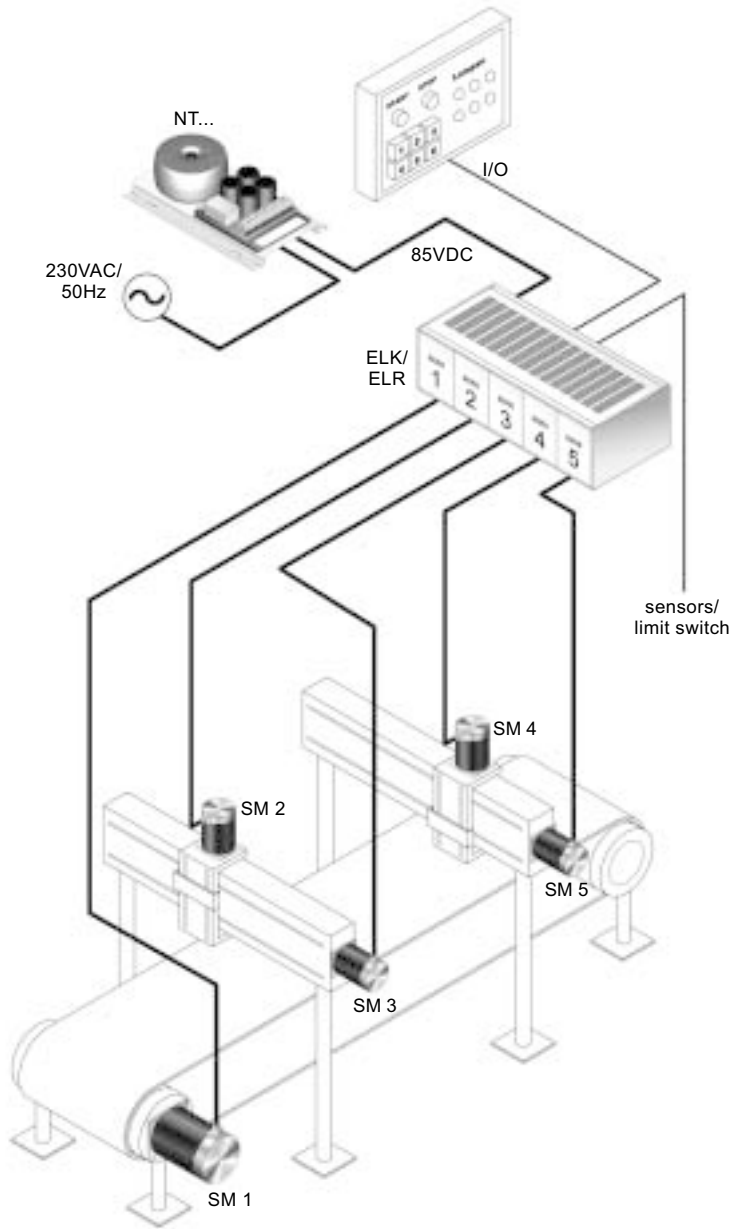
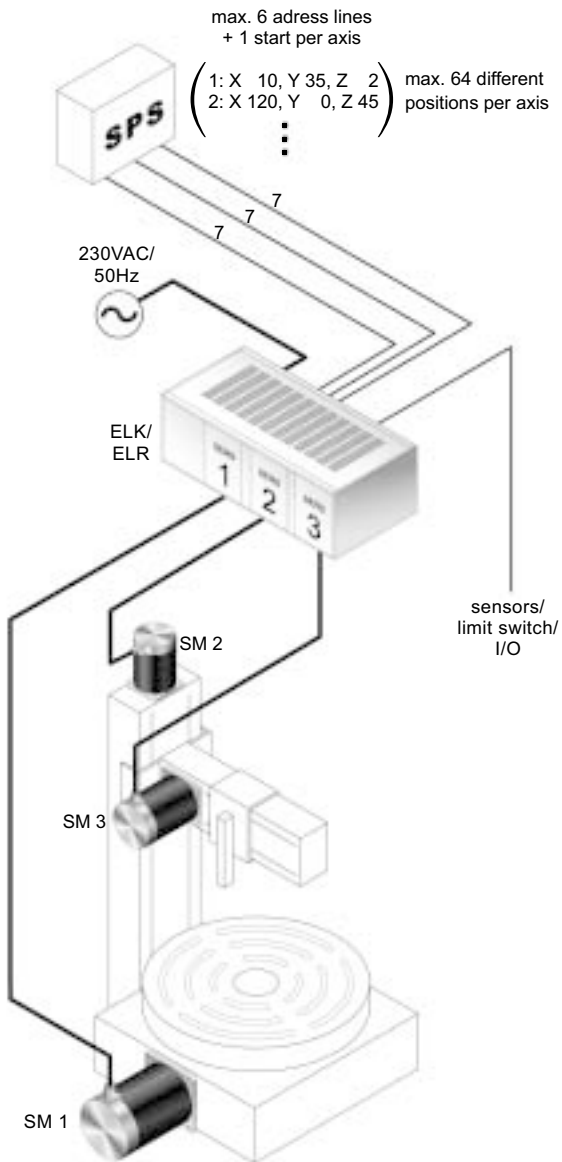

26 Position control – series SERS

Overview functions and specifications:

Power amplifier:

- excellent truth running because of **microstepping operation at 12800 steps/revolution** and four different phase current characteristics, which can be selected for matching different stepping motor types
- **phase current from 0 to 14,5A/phase, depending on version, programmable via interface**
- **power supply** depending on version 24 until 240 VDC
- protection against short circuit, over temperature and under voltage, additional pre-warning of temperature and under voltage

Inputs and outputs:

- **8 digital inputs, configurable low-/high-active (pull up or pull down input resistors), TTL (5V) or PLC (24V) – signal level**
- **2 limit switch inputs and 1 home switch input and 1 STOP switch input**
– optoisolated for 24VDC signal level
- **4 digital outputs**, each max. 500 mA / 24VDC
– optoisolated for external 24VDC supply and protected against short circuit
- **1 potential free output** – relay max. 100mA / 24VDC – usable e.g. as ready signal
- **1 analogue input** – 8 Bit, 0 to 5VDC
- Optional I/O – **extension: additional 8 digital inputs and 12 outputs**
(each max. 100mA / 24VDC)

Optionally step angle control / connection of hand wheel / electrical gearing function

- **control of motor step angle**, together with a two channel encoder (signals A, A̅, B, B̅) mounted on the motor
– 5VDC or 24VDC encoders
- **closed position loop** – lost steps (because of mechanical overload at motor) can be corrected
– encoder controls real motor position
- connection of a **hand wheel** (with 2-channel encoder signals), via the optionally encoder evaluation logic, or via two digital standard inputs

Interface:

- **RS232C/V24 (standard-PC COM-interface)**, with or without hardware handshake (selectable by software), **RS485, Profibus-DP/V0, PROFIdrive or CANopen**
- via DIP-switch adjustable baudrate from 2400 to 115200 Baud (RS232 and RS485) and drive address from 0 to 127
Profibus with baud rate until 12 MBaud (GSD-file is provided),
CANopen with baud rate until 1 MBaud (EDS file provided)

Structural shape and connections:

- euro card format (100x160), front panel and 32 pole connector (DIN 41612) for mounting into 3 HE 19 inch systems e.g. ELK-/ELR-systems – see pages 17 until 23)
- motor leads, power supply, connections for limit and home switches via 32 pole connector, or via screw / spring terminals in case of using ELK / ELR – panel mount / rack – systems.
- digital inputs and outputs via 25-pole D-Sub female connector
or optionally via additional 32 pole connector (DIN 41612)
– in case of using an ELR rack system and the SERS with additional 32 pole connector, the I/Os can be connected via spring terminals
- interface via 9-pole D-Sub connector or optionally via 32 pole connector (DIN 41612)
– when using ELR racks via spring terminals

Positioniersteuerung:

- **communication** by sending and receiving **ASCII characters** via the interface (for RS232 and RS485)
- simple and easy understandable syntax for all standard commands and parameters (see table on next page)
- programming of operational programmes similar to BASIC
- **3 different kinds of scaling** selectable for all position, speed and acceleration dates (**incremental** e.g. 5000 steps, **rotational** e.g. 1000 rpm and **linear** e.g. 20 mm/min)
- Parametrisierung von Getriebefaktoren und Vorschubkonstante (z.B. Spindelsteigung) für translatorische Werteangaben
- Velocities from 0,12 until 10000 rpm (stepping motor usable until approx. 3000 rpm, depending on motor and supply)
- acceleration from 2 until 15600 U/s² and linear, exponential or sinus acceleration characteristics
- **2 KByte E²Prom-memory** (depending on program up to **300 lines**, optionally **8 KByte** for up to 1200 lines) for storing an operational program in standalone mode, master-slave mode, parallel (BCD) mode
- backlash function for using e.g. gear boxes, chains, or spindles with backlash
- print mark control (automatical set or reset of outputs after reaching a certain position)
- travel distance after stop signal (after a stop command / signal the motor continues moving for a defined distance)
- arithmetical operations: +, -, * , /, AND, OR, EXCL-OR, NOT, NEG – usable with alle SERS parameters
1 accumulator for calculating and 12 free usable registers (R0 - R11)
- all SERS parameters can be programmed and changed anytime, also within an operational program
- Program jumps (GOTO) and subroutine calls (GOSUB)
- conditional jumps and commands (IF-commands) by query of inputs, markers, drives status and parameters, programmable with IF ... THEN ... ELSE structures
- wait function »WAIT...«, with user defined wait condition (e.g. wait for a signal at digital inputs)
- programmable delay function, with units in 10ms
- timer function (parallel to an operational program)
- counters (e.g. for realising program loops)
- manual driving functions (jog)
(without set target position, started via inputs or commands, with variable speed - can be changed during motor movement)
- extensive diagnostics – all errors and warnings can be inquired any time via the interface
- selection of language for the communication with the SERS e.g. error messages and parameter designations)
– German and English
- velocity profile mode – positioning with different speeds within one positioning job

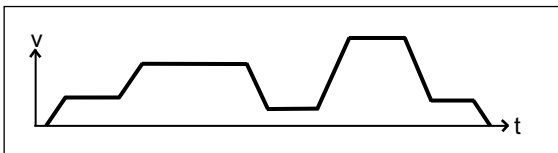

- Master-Slave-system programmable, with multiple axis (see illustration page 25), which can be synchronized to each other
 - easy realisation of the Master-Slave-system due to communication and synchronisation via RS232-interface
 - the Master-SERS may contain the complete operational program and it may control all SERS-slaves, or there will be programmed subroutines (parts of the whole program) into the slaves
 - the Master-SERS is able to read and change all parameters and use all functions of the SERS-slaves
- and many other functions (all together more than 100 different functions and parameters)

28 Position control – series SERS

Programming a SERS with RS232-interface via a PC or the SERS-Programmer 2

Software for programming a SERS with RS232 via a PC:

For SERS with RS232 interface a free programming software in DOS-version and Windows version (Win95 / 98 / NT / 2000 / XP) is provided via CD and can be downloaded from the internet.

Additionally to the manual (pdf-file on CD) an online help (windows help file) with explanations of most of the SERS-functions is included in the delivery of a SERS.

When opening the online help during running the programming software, the corresponding explanations will be displayed directly.



SERS programming-software (Win95 / 98 / ME / NT / 2000 / XP / VISTA) included in standard version

Typical standard commands in the serial operation mode:	
ON	switch on motor current
OFF	switch off motor current
V=1000	set motor velocity to 1000 (depending on adjusted scaling – e.g. rotational 1000 rpm)
W=100	set position command value to 100 – e.g. 100 mm in case of linear scaling absolute position in case of absolute positioning or distance in case of relative positioning mode
E	start positioning / execute positioning job – the drive starts positioning to the set position command value
S	Stop
POS?	request to the SERS, if the motor reached it's position – the SERS will return »POS = 0« oder »POS = 1«

Example operational program (e.g. standalone mode)	
1: L1	program label L1 (program label for jump commands)
2: WAIT I1=1	wait until input I1 is set
3: O1=0	output O1=0
4: W=55 E	position command value = 55 and start positioning (»E = execute«)
5: W=10	position = 10
6: IF I2=0 E	if input I2 is not set, then start positioning
7: O1=1	output O1=1
8: GOTO 1	jump to program label L1 (here at line 1)

Example Program BCD / parallel mode	
1: L1 ON RT	subprogram 1: Motor phase current (ON) and stop subprogram 1 (RT)
2: L2 OFF RT	subprogram 2: switch off motor current (OFF) and stop subprogram 2 (RT)
3: L3 O1=1 V=1000	subprogram 3: output O1=1, velocity V=1000
4: W=55 E O1=0 RT	Position = 55, Start Positionieren (E), after stop of positioning output O1=0 and stop subprogram 3
5: L4 O1=1 V=300	subprogram 4: output O1=1, velocity V=300
6: W=230 E O1=0 RT	Position = 230, Start positioning (E), after stop of positioning output O1=0 and stop subprogram 4
7: L5 O2=1 H O2=0 RT	subprogram 5: output O2=1, Start homing (H), after stop homing O2=0 and stop subprogram 5

SERS-Programmer 2:

- low priced programming device, in case no PC can be used
- easy to use control panel, e.g. for using in a produktion facility, for modifying parameters or program lines

Special features of the SERS-Programmer 2:

- the keypad with integrated 16x4 character display is suitable especially for dirty environments (frontside IP65 protection degree)
- colored marking of the threefold configuration of the keypad keys

Standard mode:

pre-defined standard menu with following possibilities:

- setup parameters in the SERS-control
- setup / modify operation programs in the SERS-control
- possibility of locking or releasing certain parameters and program lines via a password
- free definable text in the display for single value assignments, in an operational program
- start / stop manual drive functions (jog) and homing, via keys at the SERS-Programmer 2
- start / stop of SERS-operational programs
- start / stop of a Master-/Slave-system with one SERS as Master and further SERS as Slaves
- display of digital Inputs and Outputs (e.g. for verifying the SERS-I/Os during setup / installation of a machine)
- terminal function for communications with SERS-controls
- available as housed version (hand device), or for installing in 19" systems (e.g. STÖGRA ELK-racks), respectively for integration in any kind of control / operator panels

Extended programming mode:

- free programmable customer specific operator menus (ready menu examples exist), for realising simple menus with single level (see example below), or also menus with multiple levels
- free assignment of SERS-Programmer 2 keys to customer specific programmable functions
- operational program can be stored completely in the SERS-Programmer 2
- Master-Slave-system with SERS-Programmer as Master and all SERS drives as Slaves

Simple example for extended programming mode:

Via a SERS-Programmer 2 the machine operator shall modify just the travel distance, and he shall start and stop the operational program.

The menu, which can be accessed by the operator, shall be as simple as possible.

In the adjacent example, with key F1 the travel distance can be modified. With F3 the operational program (hidden in the background) can be started, and via the key »STOP« (unique key which is labelled with »stop«) the program respectively the motor movement can be stopped.

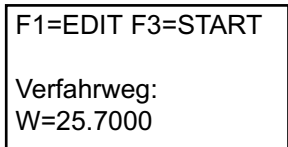

display of SERS-Programmer 2

SERS-Programmer 2 versions



SERS Programmer 2
housed hand programming device



SERS Programmer 2R
for integrating into front panels or 3-HE rack systems (ELK/ELR)

Dimensions

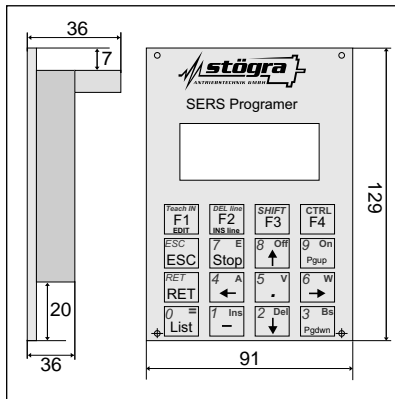

30 Position control – series SERS

Option Closed Loop Control

The SERS/WSERS is available optionally with **Closed Loop** control. The stepper motor must be a STÖGRA type with adjusted H500 encoder (motor option »C500« e.g. SM 87.2.18M6 C500). The SERS/WSERS must be ordered with option »E50/C« (e.g. WSERS 04.80 V01 E50/C).

A stepper motor system with Closed Loop control combines the advantages of stepper motors

- high response in case of short positioning movements
- no hunting at stand still
- no Gain Tuning necessary
- small load angle

with the advantage of Servo Motors (motor does not lose its synchronism – no more losing steps).

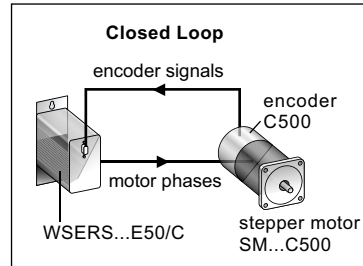

By using Closed Loop control the stepper motor can be operated always with its maximum torque.

The result is a high dynamical operation (with maximum motor acceleration).

When sizing a stepper motor system the usually planned torque safety can be reduced or maybe even skipped.

For many applications therefore a smaller motor can be selected.

Stepper Motor in open loop compared with Stepper Motor in Closed Loop Control

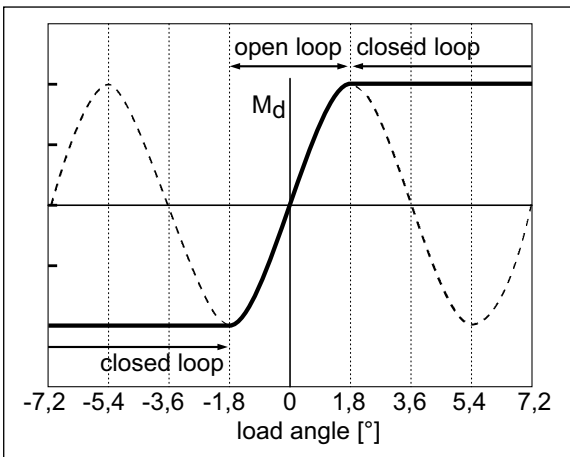

As long as the load angle is $<1,8^\circ$, the stepper motor will be operated in open loop mode.
If the load angle is $\geq 1,8^\circ$ (in open loop the motor now would lose its position) the stepper motor will be operated automatically in »closed loop mode«.

Stepper Motor in Closed Loop Control compared with a Servomotor

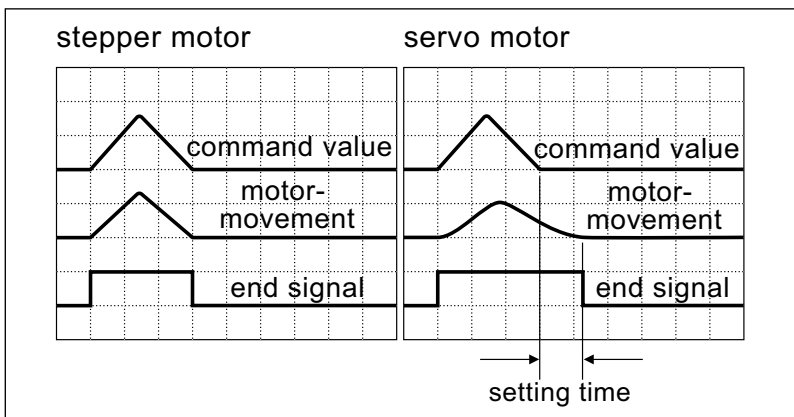

The stepper motor follows its position command values immediately (left picture).

But a SERVO motor can only start and stop with a delay / settling time, due to its system, where the position needs to be monitored continuously (right picture).

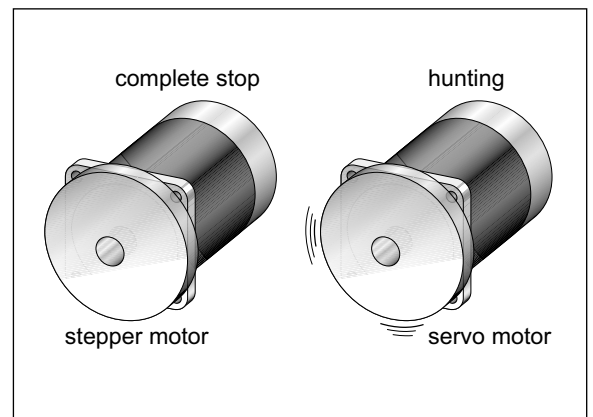

At motor stand still the stepper motor completely stands still (left picture).

But a SERVO motor is slightly moving forward and backward around its standstill position (what is called hunting – right picture).

Option **E50 encoder input**

The SERS-stepping motor control is available optionally with encoder input (SERS...V04 E50).

2-channel encoders (A, B and \bar{A} , \bar{B}) with any resolution (e.g. 2 x 50 impulses/rev. or 2 x 1000 impulses/rev.) can be connected.

The SERS... V04 E50 includes 2 different encoder signal inputs:

- **Encoder input 1** (9-pole D-Sub female connector at the SERS-front panel):

The signals are evaluated 4 times (with recognition of direction). Out of the signals of e.g. a 1000 pulse encoder there are created 4000 increments. The signals pass a RS422-input circuit and analogue and digital filters. This guarantees a very high level of noise immunity. The encoder input can be used for the control of step angle (with complete correction of lost steps after a mechanical overload at the motor – correction of actual position or driving to the target position with lower velocity) or for connecting a hand wheel or another motor (with encoder output) for realizing an electrical gearing function.

- **Encoder input 2** (inputs I3 and I4 of the digital inputs):

Signals A and B are evaluated 4-times (no evaluation of the inverted signals). This encoder input can be used for realizing a hand wheel function respective an electrical gearing function.

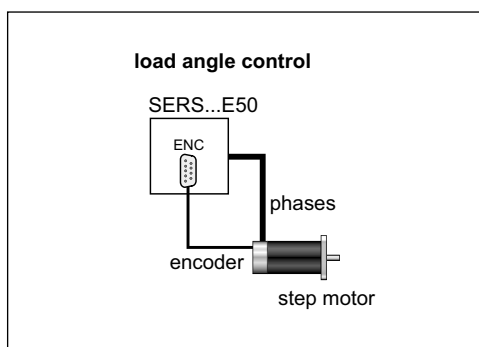

Control of load angle

The signals of an encoder mounted at the stepping motor are connected to the SERS. The SERS compares the position created by the encoder signals with the internal actual position command value.

If the difference between both values is too big (difference value adjustable), then an error message (or warning – selectable) will be created and the motor will immediately decelerate until stop (if error is preselected).

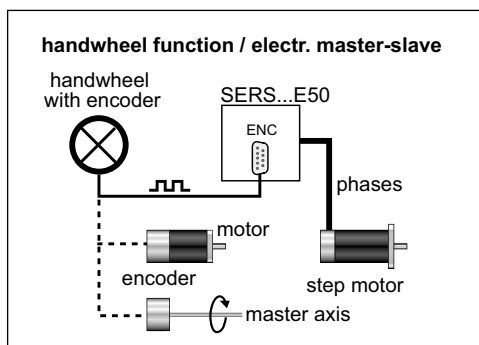

Correction of position (closed loop)

After a load angle error the lost steps can be corrected (driving with homing velocity to the position command value / target position) or the position command value is set to the real actual motor position (given by the encoder).

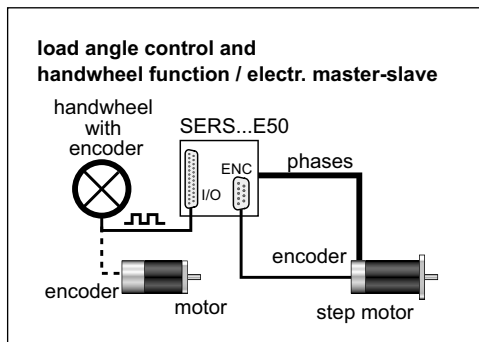

Hand wheel function / electrical gearing (master-slave) function

The signals of a hand wheel or the signals of an encoder mounted on any other shaft are connected to the SERS. The SERS (respective the motor controlled by the SERS) follows these encoder signals. The relation between the number of encoder signals (movement of the handwheel / other motor / shaft) and the movement of the stepping motor (controlled by the SERS) can be adjusted.

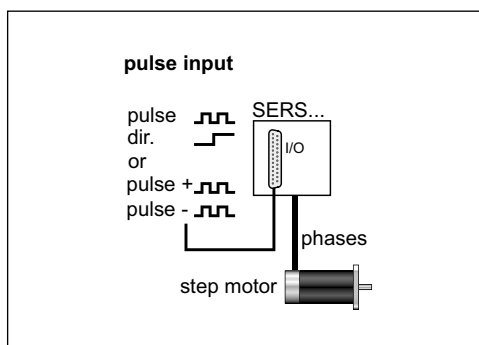

Pulse input

Encoder input 1 and encoder input 2 also may be used as pulse inputs. There are two possibilities:

1. Signal pulse and signal direction
2. Signal pulse in positive direction and signal pulse in negative direction

The movement (distance) related to one pulse can be selected via a parameter in the SERS. In case of a pulse chain with high frequency without ramp the pulses will be buffered in the SERS and the SERS creates the ramp with the preselected parameters acceleration »a« and maximum velocity »v«.

32 Position control – series SERS

SERS with Profibus-DP/V0 interface

Output	control word (4 byte)	opcode (2 byte)	operand (4 byte)	acceleration (4 byte)	velocity (4 byte)	position / travel (4 byte)
Input	status word (2 byte)	result of parameter value request (4 byte)	actual position (4 byte)	digital inputs (2 byte)		
Diagnostics	error (2 byte)	warning (2 byte)	error no. (1 byte – code for more than 100 detailed error messages)			

Control Word

the control word triggers below actions after being changed. »STOP« will be evaluated always.

Bit 0: SLOW_NEGATIVE (jog 1 = active, 0 = Stop)

Bit 2: FAST_NEGATIVE (jog 1 = active, 0 = Stop)

Bit 4: HOMING (1 = active, 0 = Stop)

Bit 6: STOP (1 = stop active, 0 = moving enabled)

Bit 8: START_POSITIONING (edge 0 to 1 = start)

Bit 13: RESET_ERROR (edge 0 to 1: P11=0)

Bit 15: EXECUTE_OPCODE (edge 0 to 1 = »opcode« will be executed)

Bit 16: START_POSITIONING_TOGGLE (at change of this bit will start the drive)

Bit 17: ABSOLUTE (positioning mode – absolute or relative)

Bit 19: POLYNOM_TERM 1 = (termination of polynom / last polynom section)

Bit 20: PARAMETER_ACCEPT (the parameter »acceleration«, »velocity« and »position command value« in bytes 11 until 22 will be used in case of a start positioning via the control word (bit 8 or bit 16).

Bit 21 bis 31: reserved

Bit 1: SLOW_POSITIVE (jog 1 = active, 0 = Stop)

Bit 3: FAST_POSITIVE (jog 1 = active, 0 = Stop)

Bit 5: PHASE_CURRENT_ON (1 = ON, 0 = OFF)

Bit 7: START_PROGRAMM (1 = Start)

Bit 9 bis Bit 12: OUTPUT 1 to OUTPUT 4 (digital outputs)

Bit 14: RESET_WARNING (edge 0 to 1 - P12=0)

Bit 18: POLYNOM 1 = (activates the polynom positioning mode)

Operation Code and Operand

Via the Operation Code bytes and the Operand bytes any SERS parameters (e.g. motor phase current) can be set.

»Operation Code« = SERS – parameter number and »Operand« = parameter value

For setting up a parameter only the correct Operation Code and value must be written into the corresponding output bytes and Bit 15 in the control word must be set.

Even complete operational programs may be saved into the SERS by using the Operation Codes and Operands.

Acceleration, Velocity and Position

Via the bytes acceleration, velocity and position a positioning job may be initialised directly. Via Bit 8 or Bit 15 in the Control Word the positioning job can be started. Bit 10 in the Status Word indicates if the target position is reached.

Status Word

In the status word the complete SERS status is shown and may be read anytime from the Profibus-Master unit.

Bit 0: READY_TO_SWITCH_ON is always 1

Bit 2: OPERATION_ENABLED (phase current ON)

Bit 4: SETPOINT_ACKNOWLEDGE (next Polynom section is expected)

Bit 7: WARNING P12 <> 0 (a warning is active)

Bit 9: REMOTE P0=0 (no running program active)

Bit 11: INTERNAL_LIMIT_ACTIVE (limit position overflow)

Bit 13: FOLLOWING_ERROR (error load angle – only for SERS with option E50)

Bit 14: ACCELERATING_PHASE (motor is accelerating)

Bit 1: SWITCHED_ON P134 <> 0 (phase current is ON)

Bit 3: FAULT P11 <> 0 (an error is active)

Bit 5 und Bit 6: not used

Bit 8: HANDSHAKE SERS (finished last opcode execution)

Bit 10: TARGET_REACHED (motor not running / position reached)

Bit 12: HOMING_ATTAINED (after successful homing procedure)

Bit 15: CONSTANT_PHASE (motor runs with constant velocity)

Result of parameter value request

For requesting the actual value of any parameter, via the Operation Code a parameter request may be started.

The actual value of the requested parameter will be written into the bytes »Result of parameter value request«.

Actual Position

The SERS writes continuously its actual position into the bytes »actual position« and can be read out at any time.

Diagnostics

In the diagnostics section all warnings and errors are indicated detailed.

E.g. during setting up new projects this gives very detailed feedback to the software engineer programming the SERS. But also at the customers application, via the diagnostics any kind of error (e.g. short circuit at motor / amplifier, warning overtemperature amplifier, STOP switch active and therefore no movement possible, invalid value set because to big or to small, and many more detailed messages) may be monitored. Over 100 different detailed error and warning messages are indicated via an error code.

GSD-file (Profibus configuration file)

A GSD-file is provided for an easy configuration of the SERS unit at a Profibus-DP master.

Also a complete manual (pdf-format) for the SERS with Profibus-DP drives is provided.

SERS with Profibus-DP/V1 interface and PROFIdrive protocol V3.1:

The SERS with PROFIdrive interface follows the specifications of the PROFIdrive profile drive technology Version 3.1.

Profibus-DP/V1 (sometimes also called Profibus-DP/V2 in case of PROFIdrive) is implemented in the SERS.

The SERS drive is an application class 4 drive, where the PROFIdrive master calculates and cyclically transmits speed setpoint values and the SERS returns actual position values and status word (closed position loop control realized via the Profibus).

A clock synchronism ensures high timing precision and exact synchronising of all connected drive axis.

This enables position interpolation with high precision and speed of multiple drive axis via the Profibus.

All SERS units with PROFIdrive also support the Profibus-DP/V0 mode (described at page 28).

Specifications of the SERS with PROFIdrive

- operation with any PROFIdrive-Master (e.g. Siemens Simotion control)
- implemented operating mode: speed control mode (application class 4)
- supported cycle times: 2ms and 4ms (for other cycle times please contact STÖGRA technical support)
- status word and control word according to PROFIdrive profile 3.1

A Profibus (PROFIdrive) configuration file (GSD-file) is provided.

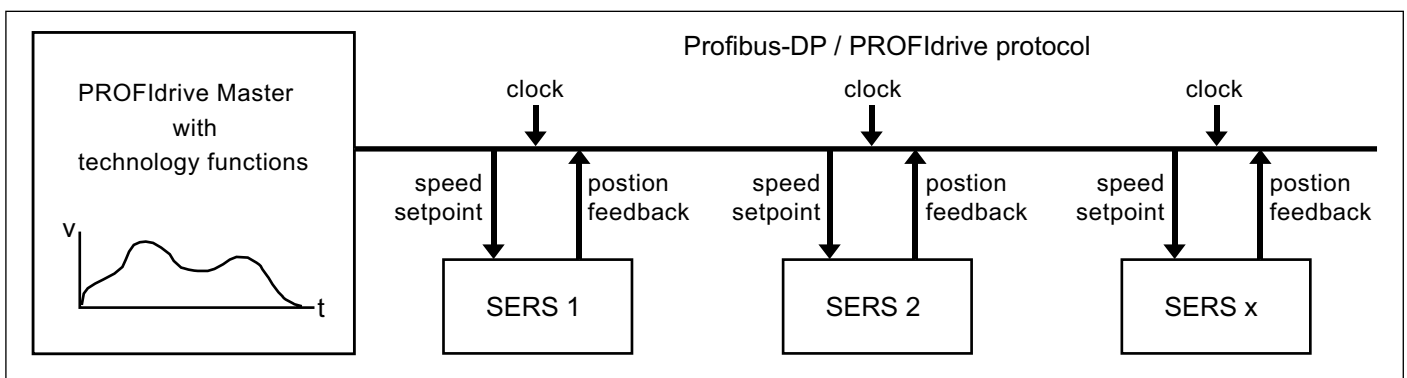

A motion profile for multiple axis (e.g. an interpolation in a 3D system with X-Y-Z axis) is given to a PROFIdrive master.

A closed position control loop via the Profibus is realised by cyclically transmitting speed setpoint values to the drives and receiving actual position values from the drives (controlled by a clock synchronism with time stamp).

For achieving the wanted position at the different axis the position feedback values are used for calculating the speed setpoint values for the next cycle.

This dynamical interpolation system also enables changing the profile at any time online, respectively generating the profile continuously (when starting the first movement, the following movements – positions and speed – are calculated online depending on any actual new events).

SERS with CANopen interface:

SERS units with CANopen interface include following specifications:

- standard parameter of the »CANopen Device Profile for Drives and Motion Control« of Index 0x6000 are according to »CiA confirming to Draft Standard Proposal **DSP-402**«
- general (e.g. communication) parameters with index numbers until 0x1000 are implemented according to »CiA Draft Standard 301« (Application Layer and Communication Profile) from »CAN in Automation e. V.«
- 11 Bit identifier used
- implemented positioning modes ("modes_of_operation" (6060)): 1 »Profile Position Mode« and 6 »Homing Mode«
- galvanically isolated CANopen interface with selectable Baudrates up to 1Mbaud
- all functions of the standard SERS with RS232 interface are implemented (see description page 22 to 27)
- EDS-file provided including reference to all manufacturer specific SERS parameter
- manual (pdf-format) provided

34 Position control – series SERS

SERS with separated 24VDC logic supply – option »U«:

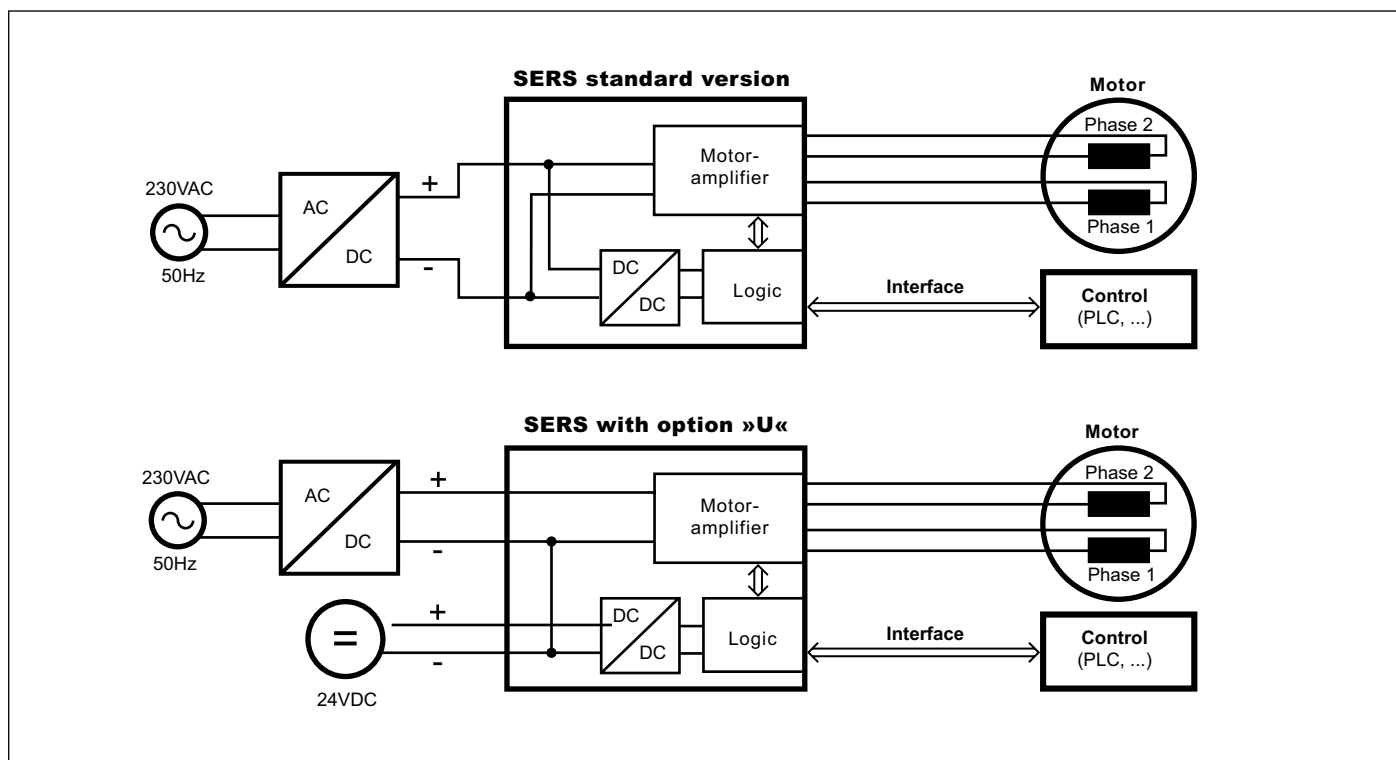

SERS standard version:

The SERS unit is supplied by an external common voltage supply (depending on SERS-version from 20 - 240VDC, respectively 230VAC in case of WSERS xx.230AC versions). This common voltage supplies the SERS-Logic as well as the SERS-power stage.

The internally needed low voltage for the SERS-Logic is generated by an internal DC/DC-stage (internal power supply).

In case of switching off the common power supply, the motor power is switched off as well as the logic (position control unit in the SERS) and the interface of the SERS.

SERS with option »U«:

SERS-controls with Option »U« (SERS ... U) need two separate voltage supplies (option »U« is recommended for controls with Profibus- or CANopen-interface, and in certain applications for SERS-controls with encoder interface):

- the motor (SERS power stage) is supplied by the main voltage (depending on SERS/WSERS version 20 - 240VDC / 230VAC)
- the Logic (position control and interface) is supplied by a separate 24VDC voltage

In case of needing to switch off the motor power (e.g. for safety reasons) the logic still can be supplied by 24VDC and therefore it still can be active (in operation).

This version may be used e.g. for keeping alive the interface (e.g. Profibus or CANopen) and its communication.

In case the switch off of the voltage supply is delayed (e.g. via a contactor with delay function) after a STOP-signal at the STOP input of the SERS, then this is a simple way of realising a »safe torque off« function.

The separate logic supply is externally via the input »service switch external« by +24VDC. The 0V (Minus) of the 24V is connected to the common GND of the SERS respective GND (24V) at ELK-racks and GND (VCC) at ELR-racks (ELK-racks must be ordered with the Option »V«).

WSERS units include separate input connections for the separate 24V supply.

As standard SERS / WSERS units do not include option »U«, this option (separate 24V logic supply) must be ordered separately (see ordering key at page 36 and 39).

SERS block diagram

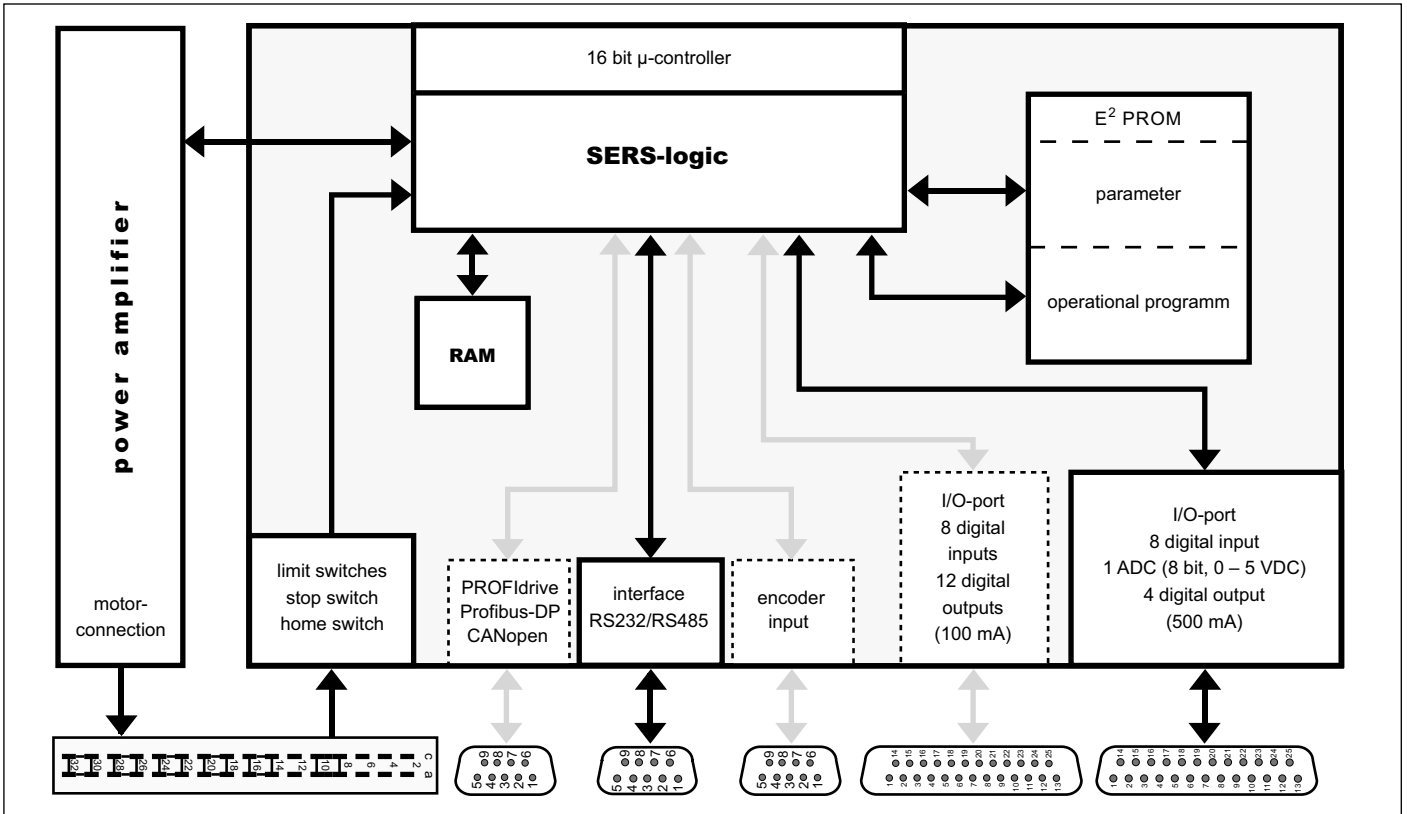

Voltage supply:

Nominal voltage	24VDC	60VDC ¹⁾	85VDC	120VDC	240VDC
Voltage supply range	20 – 40VDC	45 – 70VDC	45 – 85VDC	60 – 120VDC	120 – 240VDC

¹⁾ 60VDC versions are available only for 1A, 2A and 3A SERS boards
 Also 1A, 2A and 3A SERS boards are available only with 24VDC or 60VDC



SERS 02.60 V04
 phase current: 0 to 2,8 A/Ph
 voltage supply: 60VDC
 – optionally SERS xx.yy V04
 with xx = 01, 02, 03 or 04
 (max. 1,4, 2,8, 4,2 or 5,6A/Ph)
 and yy = 24 or 60VDC available

SERS 06.85 V04
 phase current: 0 to 8,4 A/Ph
 voltage supply: 85VDC
 optionally SERS 06.24 V04
 and SERS 06.120 V04
 with 24VDC / 120VDC

SERS 12.120 V04
 phase current: 0 to 14,5 A/Ph
 voltage supply: 120VDC
 optionally SERS 12.85 V04
 and SERS 12.240 V04
 with 85VDC respective 240VDC

ELK 3.500.85/24.2
 SERC-controls are available also in mains ready panel mount and 19 inch systems in different sizes (see ELK-/ELR-systems pages 18 to 21).
 Photo above: 2-axis-SERCOS panel mountage rack with 500VA power supply and internal 85VDC voltage supply.

36 Position control – series SERS

Dimensions

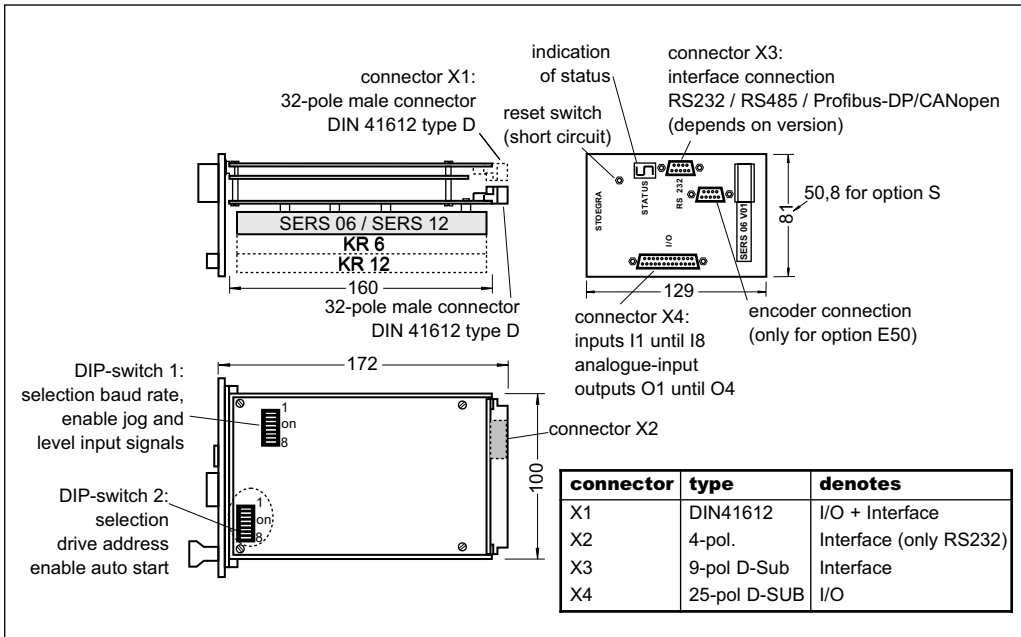

Option H:

SERS for mounting into board holder KH-SE_01 (see page 11) e.g. SERS 06.24 V04 H (board holder KH-SE_01 has to be ordered separately)



For panel mount and 19 inch systems with power supply for SERS controls → see ELK/ELR page 17

Connector options

option	X1	X2	X3	X4	description
R1	X		X		for ELR-racks – I/Os + interface via connector X1+ interface via 9-pol. D-Sub at front side
R2	X				for ELR-racks – I/Os + interface via connector X1
R3	X				for ELR-racks – I/Os + Interface via connector X1– without front panel
R4		X		X	for ELK-racks with option »I« or »I2« or »P« – interface at rear side via X2
R5		X	X	X	for ELK-racks with option »I« or »I2« or »P« – interface at front side and rear side
no indication			X	X	standard version

Ordering key (e.g. SERS 12.120 V04 or SERS 02.24 V04 E50 S or SERS 06.85 V04 R2 K6)

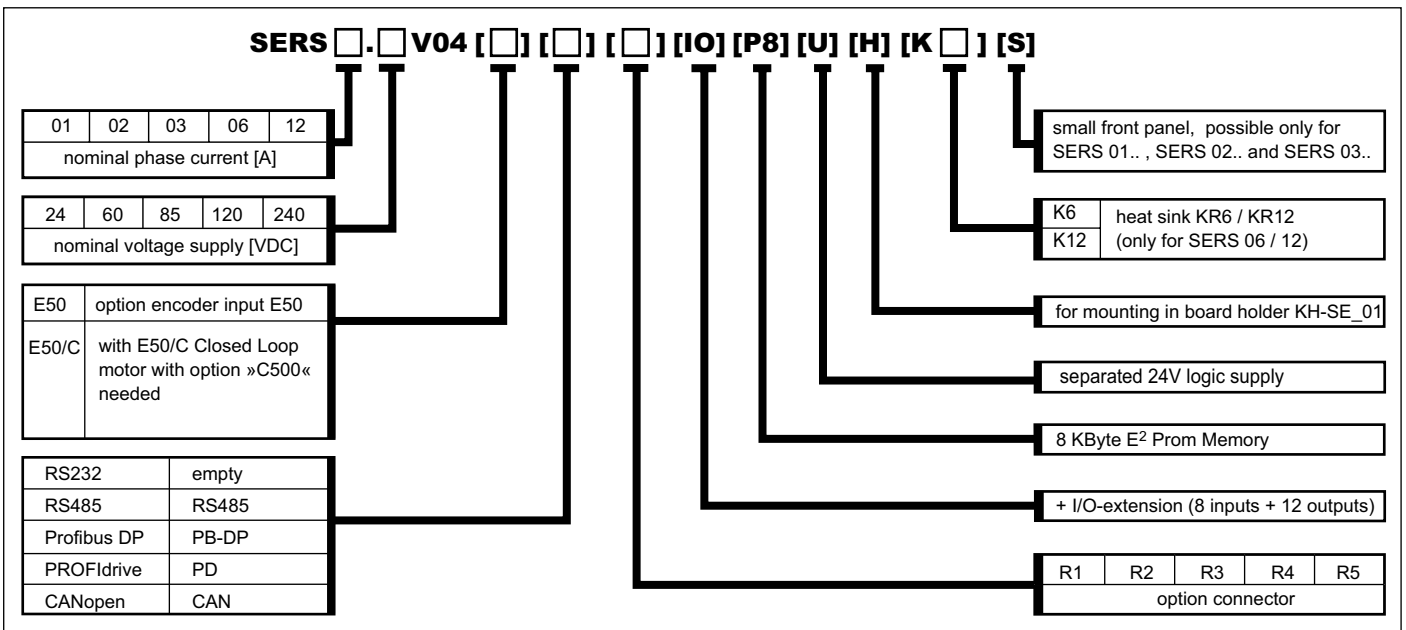

Fields in square brackets [] are for options. This field needs to be indicated, if the option is required.

1A, 2A and 3A SERS boards only available with 24VDC or 60VDC (also 60VDC only available for 1A, 2A and 3A SERS boards)

The stepping motor position control series WSERS controls 2-phases stepping motors.

A unit consists of a power amplifier, a micro-stepping power amplifier control and the position control. The communication with the position control is via an interface RS232C/V24, RS485, Profibus-DP, PROFIdrive or CANopen.

The WSERS guarantees an optimal, free of vibrations true running due to its microstepping operation with 12800 steps/revolution and the possibility to select different phase current characteristics to match the characteristics of the used stepping motor type.

The rough step by step operation of conventional stepping motor drives at low speed ranges has been improved extremely by the WSERS to a very smooth running (comparable with servo motors).

In standard version the WSERS can be operated in four different modes (see pages 24/25 – identical to series SERS).

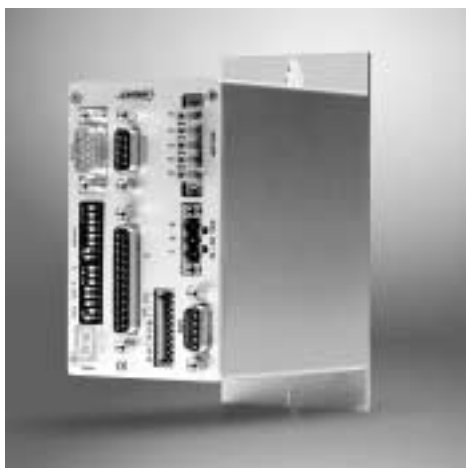

WSERS 04.80 V01 E50 PB-DP /W

phase current 0 to 4,2A/phase
voltage supply 20 to 80VDC
also available as WSERS 08.80 ...
with 0 to 8,4A/phase

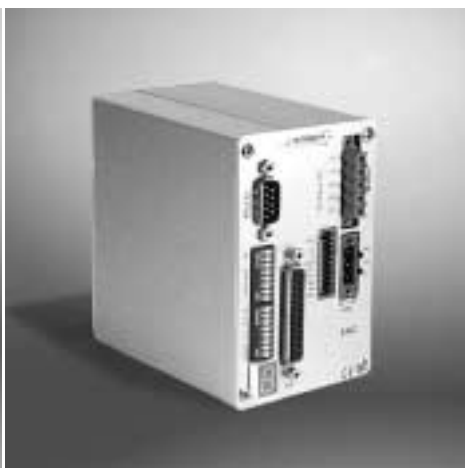

WSERS 08.80 V01

phase current 0 to 8,4A/phase
voltage supply 20 to 80VDC
also available as WSERS 04.80 ...
with 0 to 4,2A/phase

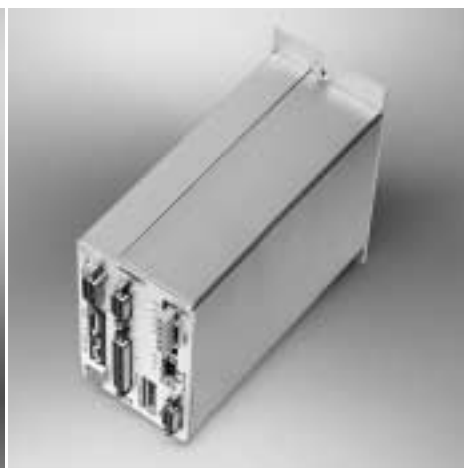

WSERS 06.230AC V01 E50 PB-DP /W

phase current 0 to 6,0A/phase
voltage supply 230VAC/50-60Hz
also available as WSERS 04.230AC ...
with 0 to 4,2A/phase

Functions of the WSERS:

The functions of the WSERS are identical to the series SERS (see descriptions on pages 26 to 31):

Inputs / Outputs (for WSERS xx.115AC and WSERS xx.230AC the analogue input is an option which must be ordered extra), optional load angle control E50, interfaces (RS232, RS485, Profibus-DP, PROFdrive, CANopen), position control, option »U« (separate logic supply), programming (via software and SERS Programmer).

As the series SERS, the power amplifier stage of the WSERS includes microstepping with 12800 steps/revolution (will be switched dynamically at higher speed).

Versions phase current and voltage supply:

type	phase current	voltage supply	internal motor operating voltage
WSERS 04.80...	0 – 4,2A/phase	20 – 80 VDC	20 – 80 VDC
WSERS 08.80...	0 – 8,4A/phase	20 – 80 VDC	20 – 80 VDC
WSERS 04.115AC...	0 – 4,2A/phase	115VAC/50-60Hz	162VDC
WSERS 06.115AC...	0 – 6,0A/phase	115VAC/50-60Hz	162VDC
WSERS 04.230AC...	0 – 4,2A/phase	230VAC/50-60Hz	325VDC
WSERS 06.230AC...	0 – 6,0A/phase	230VAC/50-60Hz	325VDC

The versions WSERS xx.115AC and WSERS xx.230AC are for direct connection to the mains 115VAC/60Hz (e.g. USA) respectively mains 230VAC/50Hz (e.g. Germany) – see also description and diagram for series WSE ...230VAC at page 10.

The AC-voltage is converted into a DC-voltage within the WSERS, resulting in a motor operating voltage of 162VDC (at 115VAC) respectively 325VDC (at 230VAC). The WSERS xx.115AC and WSERS xx.230AC may only be operated together with motors with sufficient and special insulation (e.g. from STÖGRA all motors of series SM 88, and series SM 87 and SM 107 from production date 07.2006). The motors must be suitable for being operated with 325VDC (insulation test voltage 2000VAC 1s according to VDE530-1).

Versions for DIN rail and panel mounting:

The WSERS includes a closed metallic compact housing and is available in two different mounting versions:

- version for DIN rail mounting via a rear side rail mounting clip
- version for panel mounting via a rear side panel mounting bracket

38 WSERS – connections

WSERS 04.80 and WSERS 08.80

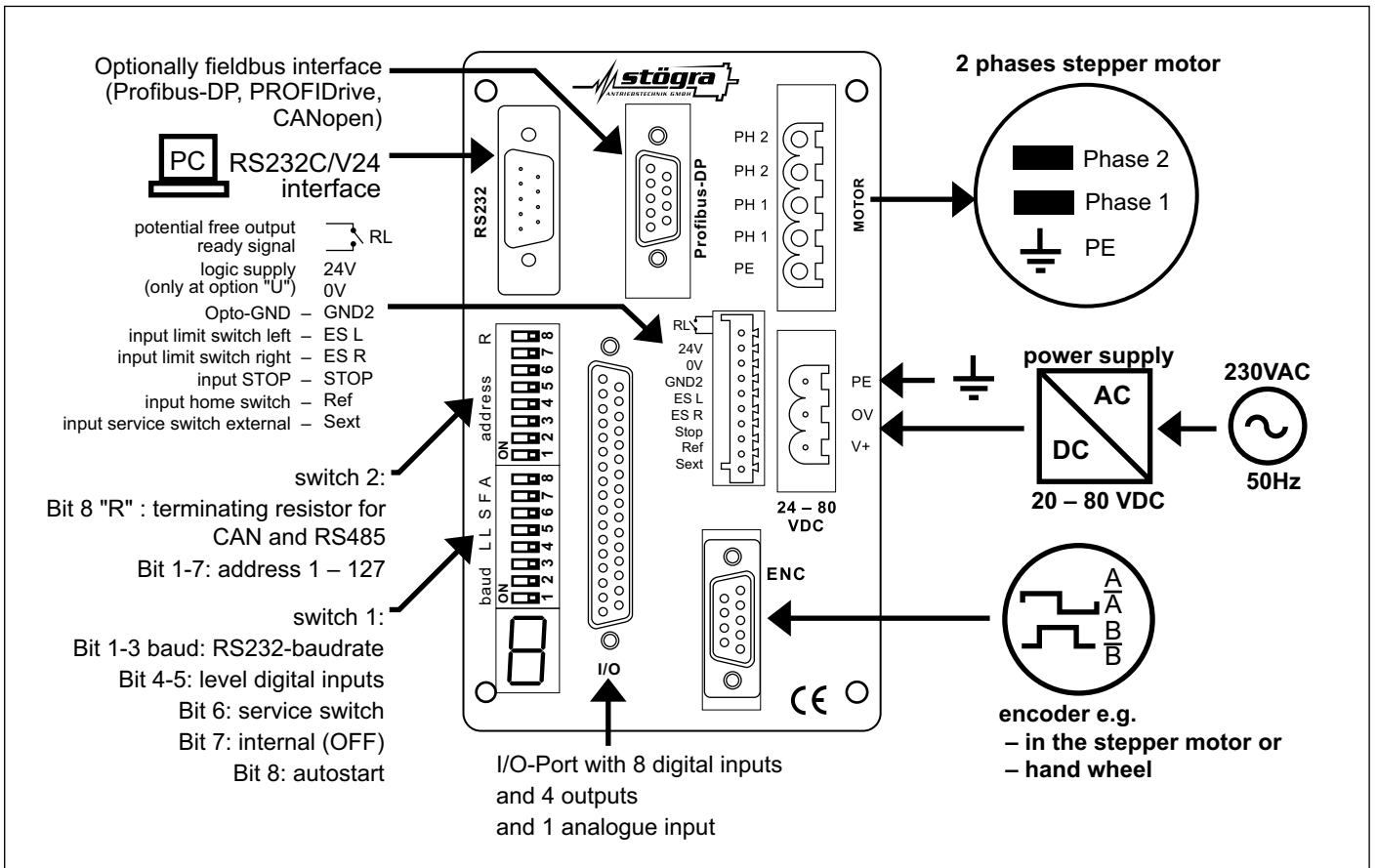

WSERS 04.230AC and WSERS 06.230AC

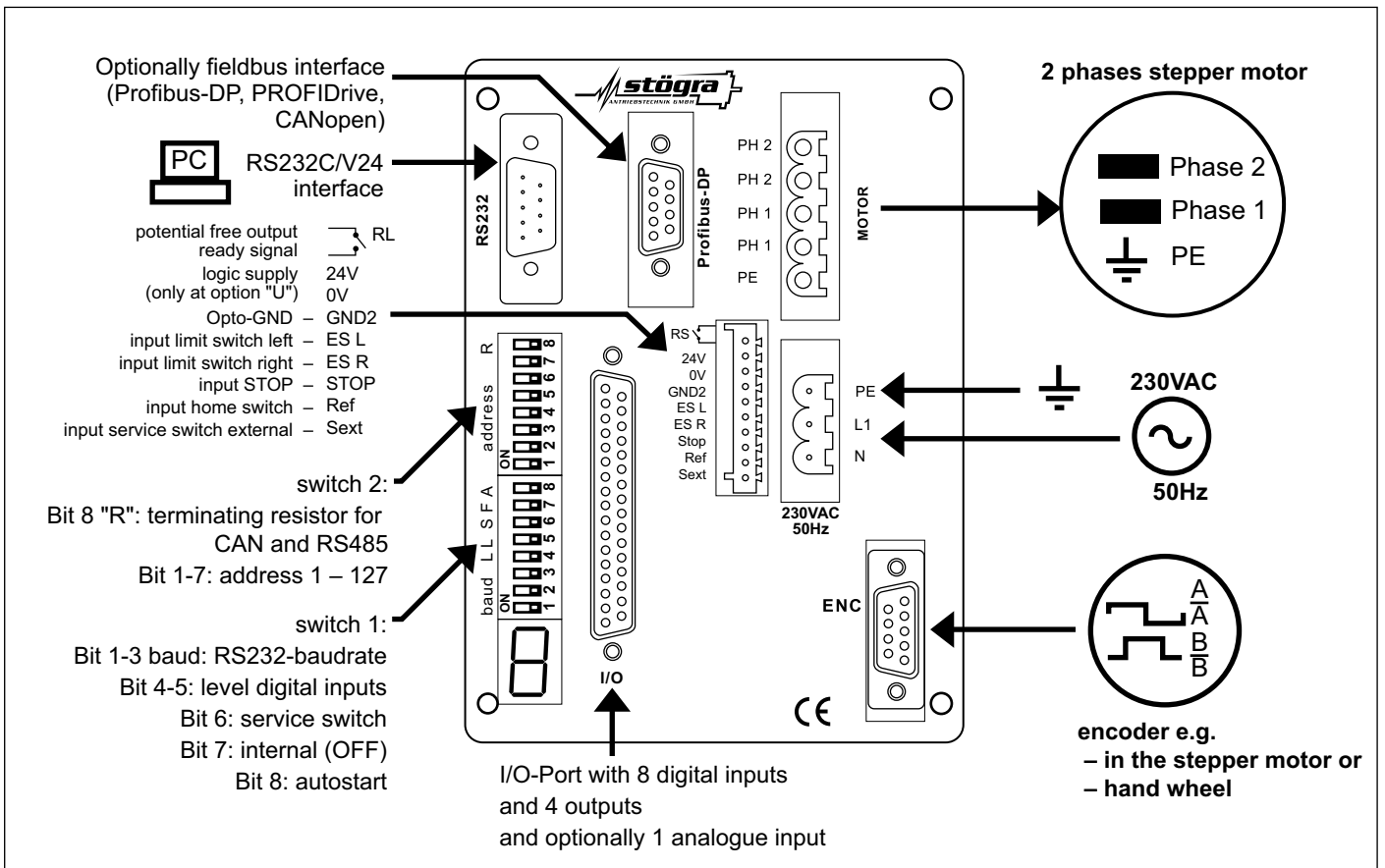

WSERS – dimensions, ordering key, specifications, equipment 39

dimensions

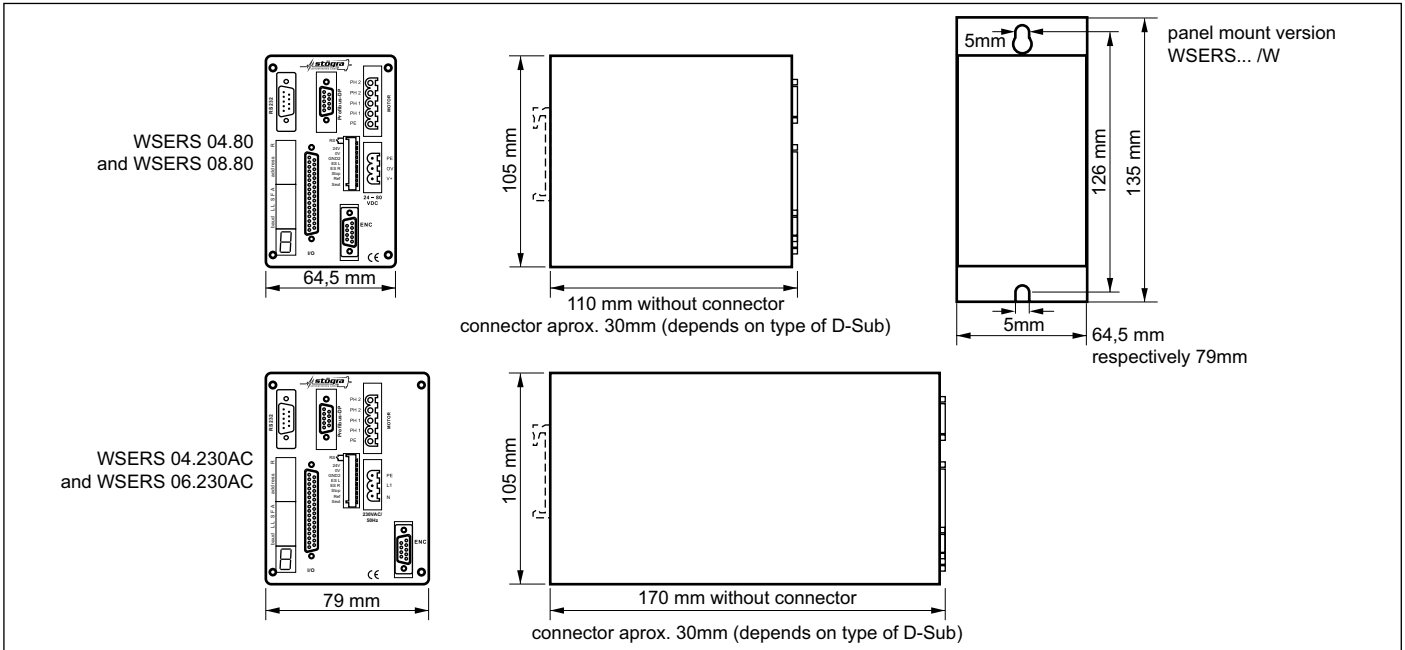

ordering key (e.g. WSERS 04.80 V01, WSERS 06.230AC V01 E50 PB-DP U, or WSERS 04.230AC V01 PD W)

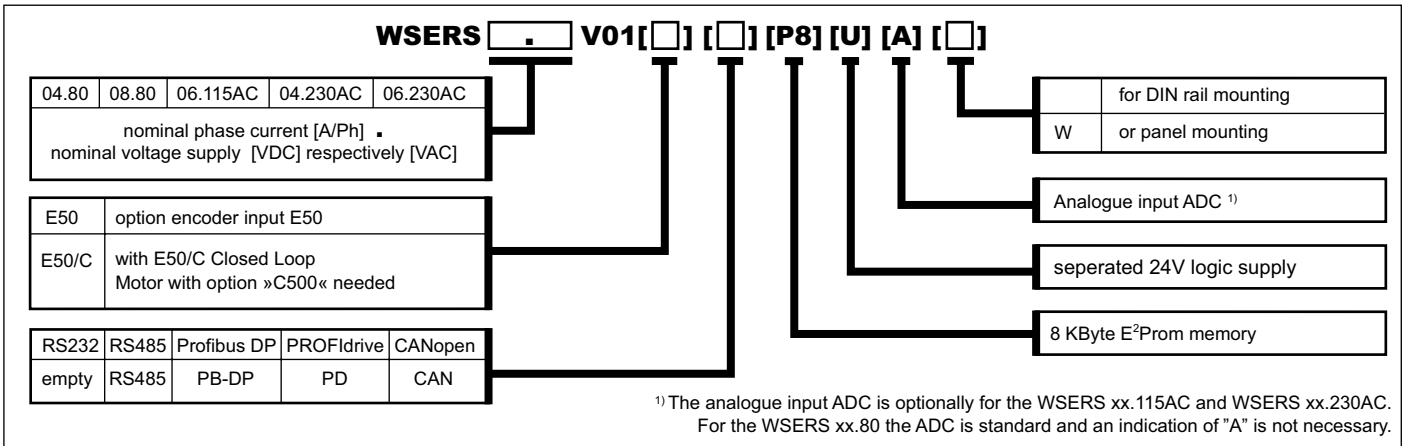

specifications WSERS

protection of device	<ul style="list-style-type: none"> protection class SERS IP00 (ELK: IP20), and WSERS IP20 protection against short circuit (motor phases), over temperature (SERS / WSERS) and under voltage 			
weight	SERS 01 / 02 / 03	SERS 06 / 12	WSERS xx.80	WSERS xx.230AC
	0,30 kg	0,60 kg	0,65 kg	1,05 kg
ambient conditions	<ul style="list-style-type: none"> ambient temperature: 0°C to 50°C forced draft: for SERS necessary from 12A adjusted phase current, for WSERS 06.230AC from 6A 			
noise immunity	if correct installed according to EN 50082-2			
noise radiation	if correct installed and shielded lines according to EN 55011 Klasse B			
RoHs conformdirective to 2002/95/EC				

equipment for SERS position controls



Screw terminal block for DIN rail mounting with 25-pole D-Sub-connector for easy connection of SERS / WSERS input/output signals via screw terminals
Ordering key: **KBDS25**

Cabel (2m) with 25-pole D-Sub connector for connecting the I/Os of a SERS / WSERS with a screw terminal block KBDS25.
Ordering key: **LDS25**



Cabel (2m) with 9-pole D-Sub connector and 1:1 wiring for the connection of the RS232-interface of a SERS / WSERS to a control (e.g. PC) with RS232-interface.
Ordering key: **LDS9**