

Connections

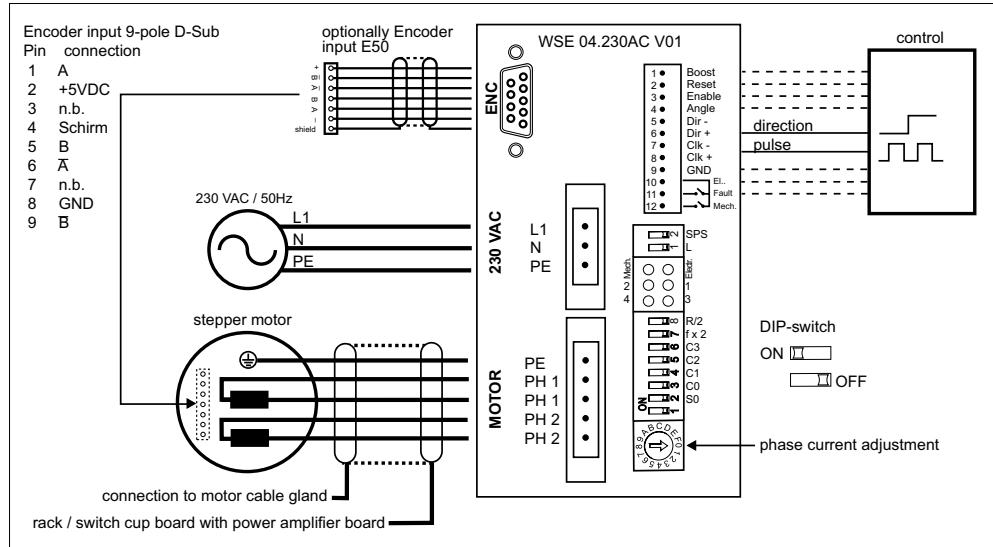

All inputs not used may stay open – it is not necessary to connect them to an external potential.
Pulse and direction are used for a normal stepper motor operation (there is no need to connect the pulse direction signal, if the motor shall run only into one direction).
All other inputs at the signal port may be connected according to the applications requirements.

Technical specifications

protection of device	protection IP 20, protection against short circuit, overtemperature und undervoltage
weight	nominal current 4 A/Ph 6 A/Ph weight 0,9 Kg 0,9 Kg
ambient conditions	ambient temperature: 0°C to 50°C, max. housing temperature: 85°C
noise immunity	in case of correct installation: according to EN50082-2: – at selected TTL-signal the inputs are not immune against fast transients (Burst)
noise radiation	In case of correct installation and shielding or/and filtering of the lines and signals according to EN55011 class B
RoHs conform to directive 2002/95/EC	

available versions: (e.g.: WSE 04.230AC V01, WSE 06.115AC V01/W, WSE 06.230AC V01, ...)

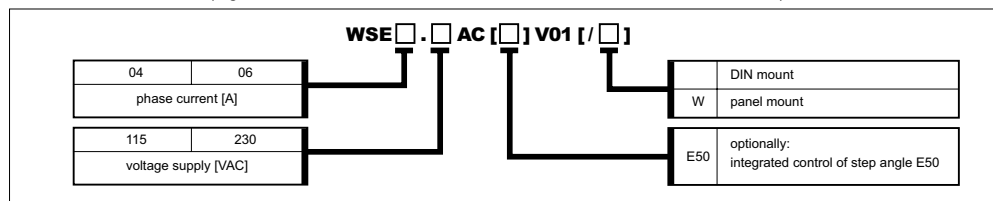

Stepper Motor Power Amplifier series WSE 04.230AC V01 and WSE 06.230 AC V01

- Bipolar 2-phases-stepper motor control
- Ready for connection directly to the mains 230VAC/50Hz
- Protected against short circuit (motor phases), over temperature and under voltage
- Selectable step resolutions via DIP switches: 200 – 12800 steps per revolution
- Selectable signal level for input signals: high-active TTL or high-active SPS (24V) or low-active
- Version WSE... E50 with control of motor load angle (stepper motor with encoder type E50 required)

Dimensions

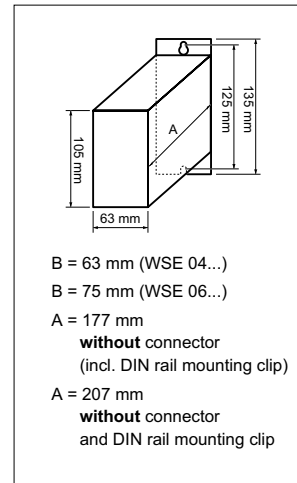

Functional diagram

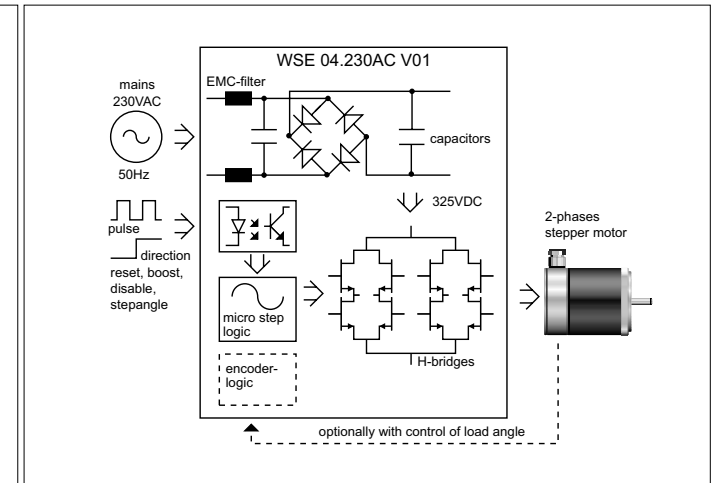

Stepper Motor specifications

Due to the internal motor voltage of 325VDC, all stepper motors operated with a WSE xx.230AC V01 power amplifier must include a sufficient insulation strength (motor winding insulation test voltage 2000VAC – 1s – according to VDE0530-1).
STÖGRA stepper motors series SM 87, SM 88 and SM 107 with production date beginning from 2004 are motors with suitable insulation strength.

Selections via DIP switches

switch	remarks	factory setting
1	E50 control ON : E50 disabled OFF : E50 enabled	OFF
2 – S0	phase current characteristics ON: SM87/SM88 OFF: SM107	OFF: SM87 / SM88
3 – C0	selection step resolution – see step angle table	OFF: 12800 steps / revolution
4 – C1	selection step resolution – see step angle table	OFF: 12800 steps / revolution
5 – C2	selection step resolution – see step angle table	OFF: 12800 steps / revolution
6 – C3	selection step resolution – see step angle table	OFF: 12800 steps / revolution
7 – f x 2	double step – see separate description	OFF: no double step
8 – R/2	current reduction at stand still ON: I = 100% OFF: I = 50%	OFF: current reduction active
9 – L	signal level input signals – see separate description	OFF: high active
10 – SPS	signal level input signals – see separate description	OFF: TTL

Selection of step angle / resolution

Different step angles can be selected via the switches C0, C1, C2 and C3. With the input »angle« the step angle can be switched externally between two values (works only if switch »W« is open!). During motion, switching the step angle is possible within the motor start-stop-frequency (when changing simultaneously the pulse frequency and step angle – at any frequency).

step / revolution resolution externally switchable via the input »Angle«		DIP-switch 3 – 6 for selection of steps / revolution X = ON, else = OFF			
input not active	input active	C0 (switch 3)	C1 (switch 4)	C2 (switch 5)	C3 (switch 6)
200	200	X	X	X	X
400	200	X	X	X	
500	500	X	X		X
800	400	X	X		
1000	500	X		X	X
1600	400	X		X	
2000	400	X			X
2500	500	X			
3200	800		X	X	X
4000	400		X	X	
5000	500		X		X
6400	400		X		
8000	500			X	X
10000	400			X	
10000	1000				X
12800	800				

for other step angles / resolutions please contact us

Double pulse (switch 7 »f x 2«)

If the switch 7 (f x 2) is ON, then each signal edge at the pulse input will result in the execution of a motor set (rising edges and falling edges will execute motor steps)

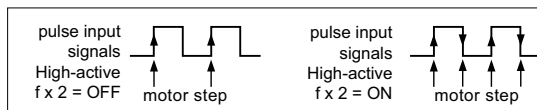

Automatical phase current reduction (switch 8 »R/2«)

If the switch 8 (R/2) is ON, then the phase current at motor standstill will be reduced by 50%. The first coming pulse will rise the phase current again to 100%. If a signal is active at the reset input, then the current reduction will not be activated.

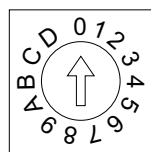

Phase current adjustment

Ex factory the power amplifier is set to 2A (WSE 04...) and 3A (WSE 06...). The phase current must be set to the bipolar phase current of the connected stepper motor. The adjustment is done via the rotational switch at the front side of the WSE according to below table. The table value corresponds to the bipolar phase current of the motor.

type / switch position	0	1	2	3	4	5	6	7	8	9	A	B	C	D	E	F
4 A/Ph. SE ...04...	0,00	0,27	0,53	0,8	1,07	1,33	1,6	1,87	2,13	2,4	2,67	2,93	3,2	3,47	3,73	4
6 A/Ph. SE ...06...	0,00	0,4	0,8	1,2	1,6	2	2,4	2,8	3,2	3,6	4	4,4	4,8	5,2	5,6	6

Input- / Output signals description

- Boost:** phase current is increased by 20%
- Disable:** phase current in the motor phases will be shut off
- Reset:** Drive errors are reset, drive in reset position (phase zero), pulse signals are disabled
- Dir:** Control of motor direction
- Clk:** Each pulse executes one motor step
- Angle:** The step resolution will be changed – see step angle / resolution table above
- Ready signal:** An **electrical error** (under voltage, short circuit or over temperature) or a **mechanical error** (only E50 versions) will open the relay contact. Other wise the relay contact is closed (ready for operation)

input signals

Signal rise time max.: 1µs, signal fall time max.: 1µs, frequency pulse max.: 200 KHz

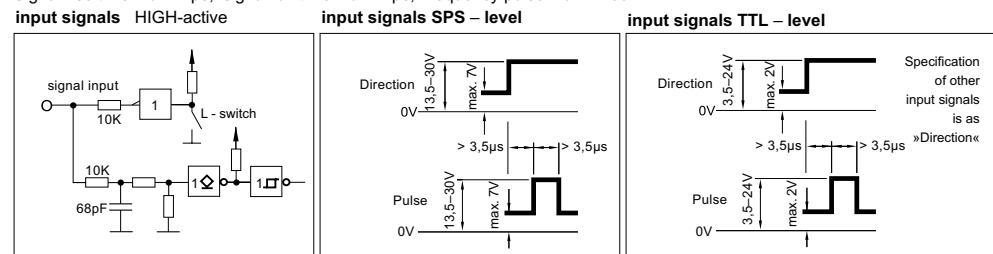

input signals – adjustment signal level – switch »SPS« and »L«

signal specifications	switch »L«	switch »SPS	connection »Clk« and »Dir« at signal plug port
High-active TTL	OFF	OFF	Clk- and Dir- (Clk+ and Dir+ are not connected)
High-active SPS	OFF	ON	Clk- and Dir- (Clk+ and Dir+ are not connected)
Low-active	ON	OFF	Clk+ and Dir+ (Clk- and Dir- are not connected)
not valid	ON	ON	
RS422	OFF	OFF	Clk+ and Clk- and Dir+ and Dir- (all other signals High-active SPS)
RS422	OFF	ON	Clk+ and Clk- and Dir+ and Dir- (all other signals High-active TTL)

In case of set modes »High-active« and »Low-active« the connection »GND« has to be connected with the control sending the signals »Clk« and »Dir«.
In case of a set mode »RS422« the connection »GND« has to be connected only in case other signals than »CLK« and »Dir« shall be used additionally.

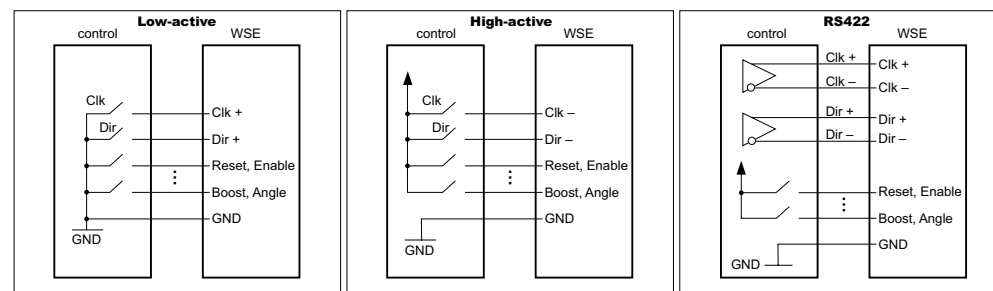

output-ready signal

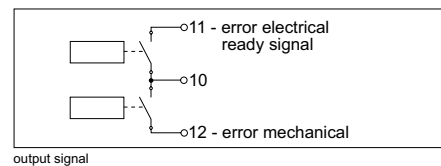

voltage supply

WSE ... 230AC V01: 230 VAC / 50 – 60 Hz
Internally 325VDC are created (motor voltage)
WSE ... 115AC V01: 115 VAC / 50 – 60 Hz
Internally 162VDC are created (motor voltage)

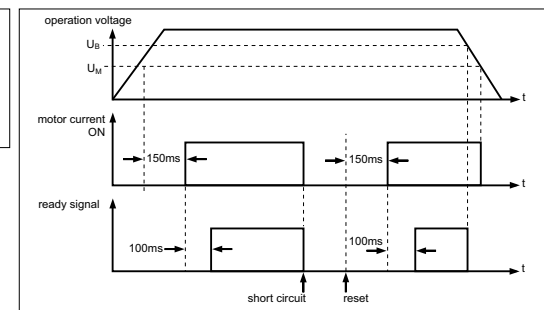

Timing output-ready signal